

# ExaCut

## ECQ48-40

### Operating instructions

Date of issue: 2020-07-07

Original operating instructions

**Manufacturer**



Holthöge 10-14  
Tel: +49 5434 83-0  
Fax: +49 5434 83-10  
49632 Essen (Oldenburg), Germany  
Email: [info@vogelsang.info](mailto:info@vogelsang.info)  
Web: <http://www.vogelsang.info>

© Vogelsang GmbH & Co. KG

# Table of contents

|          |   |           |
|----------|---|-----------|
| <b>1</b> | <b>About this manual</b>                                      | <b>6</b>  |
| 1.1      | Information about this manual                                 | 6         |
| 1.2      | Conventions used in this document                             | 6         |
| 1.2.1    | Warning messages  | 6         |
| 1.2.2    | Symbols   | 7         |
| 1.2.3    | Figures   | 7         |
| 1.3      | Other applicable documents                                    | 7         |
| 1.4      | Directional information                                       | 8         |
| 1.5      | Target group  | 8         |
| <b>2</b> | <b>Safety</b>   | <b>9</b>  |
| 2.1      | General safety information                                    | 9         |
| 2.1.1    | Intended use  | 9         |
| 2.1.2    | Foreseeable misuse  | 10        |
| 2.2      | Operator's responsibilities                                   | 10        |
| 2.2.1    | Personal protection equipment                                 | 12        |
| 2.3      | Safety notes  | 13        |
| 2.3.1    | Safety notes for particular phases in the life of the product | 13        |
| 2.3.2    | Safety notes for particular types of dangers                  | 14        |
| 2.4      | Danger areas  | 15        |
| 2.5      | Warning and safety stickers                                   | 16        |
| <b>3</b> | <b>Product description</b>                                    | <b>18</b> |
| 3.1      | Overview  | 18        |
| <b>4</b> | <b>Specifications</b>   | <b>19</b> |
| 4.1      | DosiMat   | 19        |
| 4.2      | Requirements for the vehicle hydraulics                       | 19        |
| 4.3      | Hydraulic motor   | 20        |
| 4.4      | Hydraulic oil   | 22        |
| 4.5      | Oil filter  | 23        |
| 4.6      | Name plate  | 23        |
| <b>5</b> | <b>Storage</b>  | <b>26</b> |
| <b>6</b> | <b>Transport</b>  | <b>27</b> |
| 6.1      | Safety notes  | 27        |
| 6.2      | Permissible transport options                                 | 28        |
| 6.2.1    | Transporting the machine while suspended                      | 28        |
| 6.2.2    | Transporting the machine on a Euro pallet                     | 28        |
| <b>7</b> | <b>Installation</b>   | <b>29</b> |
| 7.1      | Safety notes  | 29        |

|           |  |           |
|-----------|--|-----------|
| 7.2       | Assembly instructions .....                                | 31        |
| 7.3       | Mounting the DosiMat on the spreader vehicle .....         | 32        |
| 7.4       | Connecting the hydraulics .....                            | 33        |
| 7.4.1     | Safety notes .....   | 33        |
| 7.4.2     | Connecting hydraulic hoses .....                           | 34        |
| 7.5       | Reversing function .....                                   | 37        |
| 7.6       | Installing sensors .....                                   | 37        |
| 7.7       | Installing the supply hose .....                           | 37        |
| 7.8       | Mounting ventilation hoses .....                           | 38        |
| 7.9       | Mounting the discharge hoses .....                         | 38        |
| 7.9.1     | Hose connection diagram .....                              | 40        |
| <b>8</b>  | <b>Start-up .....</b>                                      | <b>41</b> |
| 8.1       | Safety notes .....   | 41        |
| 8.2       | Start-up sequence .....                                    | 43        |
| 8.3       | Checklist .....  | 44        |
| 8.4       | Starting the hydraulic system .....                        | 44        |
| <b>9</b>  | <b>Operation .....</b>                                     | <b>45</b> |
| 9.1       | Safety notes .....   | 45        |
| 9.2       | Operating instructions .....                               | 47        |
| 9.3       | Reverse .....  | 49        |
| <b>10</b> | <b>Maintenance .....</b>                                   | <b>50</b> |
| 10.1      | Lubricants .....   | 50        |
| 10.2      | Tightening torques .....                                   | 51        |
| 10.3      | Spare parts .....  | 52        |
| 10.4      | Maintenance intervals .....                                | 52        |
| 10.4.1    | Before start-up .....                                      | 52        |
| 10.4.2    | After the first 20 operating hours .....                   | 53        |
| 10.4.3    | Every 50 operating hours .....                             | 54        |
| 10.4.4    | Every 2000 operating hours, at least every 12 months ..... | 55        |
| 10.4.5    | Every 6 years .....  | 55        |
| 10.4.6    | Before longer periods of shutdown .....                    | 56        |
| 10.4.7    | After long periods of shutdown .....                       | 56        |
| 10.5      | Maintenance tasks .....                                    | 57        |

|           |   |            |
|-----------|---|------------|
| 10.5.1    | Safety notes .....  | 58         |
| 10.5.2    | Switching off the distributor .....                             | 60         |
| 10.5.3    | Dismounting the service port .....                              | 61         |
| 10.5.4    | Installing the service port .....                               | 62         |
| 10.5.5    | Tightening screw and bolt connections .....                     | 63         |
| 10.5.6    | Tightening the nuts on the hydraulic motor .....                | 65         |
| 10.5.7    | Cleaning the DosiMat .....                                      | 66         |
| 10.5.8    | Replacing wear parts .....                                      | 67         |
| 10.5.9    | Changing the gaskets .....                                      | 76         |
| 10.5.10   | Checking the drive adapter for leaks .....                      | 89         |
| 10.5.11   | Lubricating drive adapter .....                                 | 90         |
| 10.5.12   | Checking hydraulic hoses and fittings .....                     | 92         |
| <b>11</b> | <b>Malfunctions and errors .....</b>                            | <b>94</b>  |
| 11.1      | Safety notes .....  | 94         |
| 11.2      | Table of malfunctions .....                                     | 97         |
| 11.2.1    | DosiMat is vibrating .....                                      | 97         |
| 11.2.2    | Cutting effect insufficient .....                               | 98         |
| 11.2.3    | Poor distribution .....   | 98         |
| 11.2.4    | Only a few discharge hoses are being supplied with medium ..... | 98         |
| 11.2.5    | Strong pulsation in the discharge hoses .....                   | 99         |
| 11.2.6    | Noises in the hydraulic system .....                            | 99         |
| <b>12</b> | <b>Disassembly .....</b>  | <b>100</b> |
| 12.1      | Safety notes .....  | 100        |
| 12.2      | Dismounting the DosiMat .....                                   | 103        |
| <b>13</b> | <b>Disposal .....</b>   | <b>104</b> |
| 13.1      | Safety notes .....  | 104        |
| 13.2      | Measures for disposal .....                                     | 105        |
| <b>14</b> | <b>Appendix .....</b>   | <b>106</b> |
| 14.1      | Declaration of installation .....                               | 106        |
| 14.2      | Dimension Drawing .....   | 108        |
| 14.3      | Data Sheet .....  | 109        |
| 14.3.1    | Pressure sensor .....   | 109        |
| 14.3.2    | Speed sensor .....  | 113        |
| 14.4      | Service plan .....  | 116        |

# 1 About this manual

## 1.1 Information about this manual

This manual contains all of the information needed to use the machine properly, effectively and safely.

- This manual must always be available to anyone who works with the machine.
- You must read the manual before you start to operate the machine.
- This manual is an integral part of the machine. If the machine changes hands, then this manual must be passed on to the new owner.

Additional copies of the manual are available upon request.

Vogelsang will not accept any liability for damage resulting from failure to comply with this manual.

## 1.2 Conventions used in this document

### 1.2.1 Warning messages

#### **DANGER!**

"Danger" indicates a dangerous situation which directly leads to death or serious injury.

---

#### **WARNING!**

"Warning" indicates a dangerous situation which can directly lead to death or serious injury.

---

#### **CAUTION!**

"Caution" indicates a potentially hazardous situation which may result in minor to moderate injury.



---

#### **NOTICE!**

"Attention" indicates a situation which can lead to material damage and environmental damage.

---

## 1.2.2 Symbols

| Symbol  | Meaning                                     |
|---|---|
|  | Instructions for use and useful information |
|  | Environmental protection notices            |

## 1.2.3 Figures

The figures used in this manual are only intended for the purposes of understanding and illustration.

If original drawings are supplied, the information and illustrations which they contain are binding. In the event of any discrepancies, the original drawings take precedence over the figures in this manual.

## 1.3 Other applicable documents

All of the documents which are mentioned or attached to this manual are considered an integral part of it. You must observe and follow the instructions in the other applicable documents.

If you do not have access to some of the other applicable documents, contact Service.

## 1.4 Directional information

Directional information in these operating instructions, such as front, back, right and left are always relative to the direction of motion when the attachment is in its working position.

## 1.5 Target group

These operating instructions are intended for the following persons:

- The person who bears the responsibility for the system (i.e. its operator)
- Service technician, installer
- Operator
- Service personnel

### Personnel qualifications

The activities described in this manual may be carried out only by persons

- who have been trained for the activities concerned and who possess the necessary knowledge.
- who have been informed about the possible dangers when using the machine.

### Qualifications for particular tasks

- Transport and loading: crane operators and forklift drivers with appropriate authorization
- Work on the electrical system: qualified electricians
- Work on the hydraulic system: qualified hydraulic personnel
- Connecting and checking safety devices: qualified technical personnel, (e.g. mechanics, metalworkers, technicians or persons with comparable training)

If specific additional qualifications are required to carry out work, these will be specified in the section concerned.



## 2 Safety



### Notice

- Follow all of the safety instructions in this manual and in the other applicable documents. Following these instructions provides for your own safety.
- Please contact us immediately in the event of any irregularities in connection with the safety of the delivered product:

**[produktsicherheit@vogelsang.info](mailto:produktsicherheit@vogelsang.info)**

## 2.1 General safety information

### 2.1.1 Intended use

The DosiMat is a machine for the precise distribution of natural fertiliser—including liquid manure, biogas manure and digestate (referred to as the "medium" in the following)—to varying numbers of discharge hoses.

The DosiMat can be operated on a spreader vehicle, or as a fixed installation under a roof or canopy.

The DosiMat can be operated on vacuum tankers and pump tankers.

The permissible range of temperature for the medium is 0 °C to 45 °C.

### NOTICE!

If the DosiMat is operated on a pump tanker, the operating pressure must be limited to 2 bar. Otherwise the DosiMat could burst.

- ▶ Limit the operating pressure to 2 bar (e.g. with a pressure relief valve).  
We recommend using a pressure gauge on the supply line to monitor the pressure.

In addition to the specifications in this chapter, those in the "Specifications" chapter must be complied with as well, → 4 *Specifications*.

### 2.1.2 Foreseeable misuse

The following points are contrary to the intended use and represent misuse:

- The DosiMat is used otherwise than as described in the "Intended use" section.
- The safety notes in this manual are ignored.
- The specified maintenance and inspection work has not been done at the required times.
- The medium is above or below the permissible temperature.
- The DosiMat is:
  - used in a potentially explosive atmosphere.
  - used in the food industry.
  - used to spread flammable fluids.
  - used to spread non-pumpable media.
  - used in a closed space.
  - operated by persons who are not trained or instructed.
  - improperly changed or modified.
  - operated with spare parts or accessory parts that are not approved by the manufacturer.

The manufacturer is not liable for damage resulting from improper use.

## 2.2 Operator's responsibilities

The machine is used commercially. The machine's operator is thus subject to the local statutory regulations on occupational safety and environmental protection.

The operator must ensure that

- the machine remains in full working order at all times.
- the machine is only operated within its technical limits.
- all of the maintenance intervals specified in this manual are adhered to and documented.
- the instructions in this manual are followed.

In addition, the operator must

- inform the personnel about the nature and operating temperature of the medium and about hazardous substances, e.g. in working materials, and take appropriate safety measures.
- define which persons are responsible for which actions performed on the machine.
- ensure that all persons who handle the machine,
  - have been trained in the tasks they are expected to perform.
  - and have been informed of the potential risks involved in working with the machine.







**Notice**

Take the opportunity to have your staff trained by Vogelsang.

---

## 2.2.1 Personal protection equipment

The following personal protective equipment must be available to the personnel:

| Personal protective equipment   | Meaning            |
|---|--------------------|
|    | Safety goggles     |
|    | Safety helmet      |
|   | Hearing protection |
|  | Safety gloves      |
|  | Safety shoes       |

## 2.3 Safety notes

### 2.3.1 Safety notes for particular phases in the life of the product

#### Installation

- When lifting and moving heavy parts, use appropriate hoists.
- Only use hoists designed for the weight concerned.
- Use the specified slinging points.

#### Operation

- Before starting work, familiarise yourself with all of the machine's equipment, controls and functions.
- Only operate the machine
  - if all protective and safety devices are functional.
  - if access to the danger areas is not possible.
- Do not work in any way that could pose a risk to safety.

#### Malfunctions

- In case of malfunctions, stop the machine immediately.
- Clear the malfunction immediately.

#### Maintenance, repair

- Do the specified maintenance work punctually.
- Switch off the machine before doing any maintenance or repair work.
- Use only genuine spare parts or parts approved by Vogel-sang.
- Install spare parts correctly.
- Once the work has been completed, install and check any removed safety devices.

#### Disposal

- Sort residual medium, pollutants and replacement parts according to their type and dispose of them in an environmentally-friendly manner.
- When handling a medium, always observe the valid safety instructions for the substance concerned.
- Avoid contact with pollutants. Wear suitable protective clothing.

## 2.3.2 Safety notes for particular types of dangers

### Electrical energy

- Allow only qualified electricians to work on electrical systems or equipment.
- In the event of malfunctions in the electric power supply, immediately shut down the machine or the system.

### Hydraulics, pneumatics

- Only persons with special knowledge and experience in hydraulics may work on hydraulic equipment.
- Hydraulic and compressed air lines must be routed and installed correctly.
- Do not mix up connections.
- Valves, fittings, and the length and quality of the hoses must comply with the requirements.

### Oils, greases and other chemical substances

- When handling oils, greases and other chemical substances, observe the applicable safety regulations.
- Wear suitable protective clothing when handling hot or hazardous operating or auxiliary materials or the medium to be spread.
- Dispose of oils, greases and other chemical substances in an environmentally friendly manner.

### Heavy parts

- Use an appropriate hoisting device and tools to lift and move heavy parts.

### Special ambient conditions

#### Risk of frost

In the event of frost, the medium could freeze in the DosiMat. This could cause damage to the DosiMat.

Before long periods of shutdown, clean the DosiMat, → 10.5.7 *Cleaning the DosiMat*.

## 2.4 Danger areas

The following areas at the distributor are danger areas:

- In the area under the cleaning port
- Inside the distributor
- In the area around the service ports

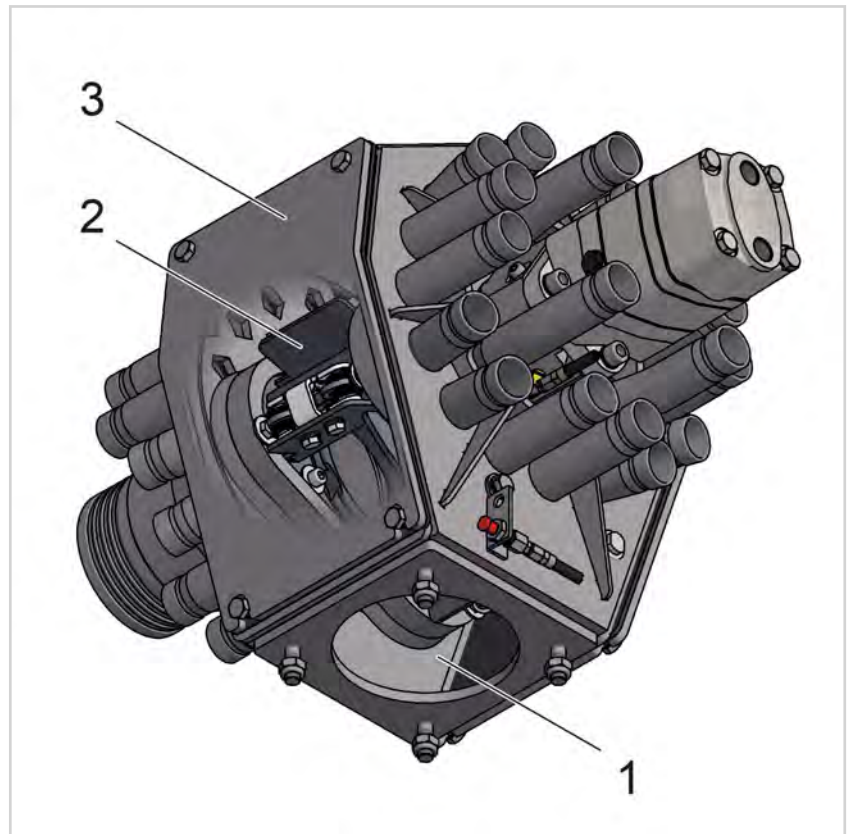

Fig. 1: Danger areas

- |   |  |                             |   |  |              |
|---|--|-----------------------------|---|--|--------------|
| 1 |  | Cleaning port               | 3 |  | Service port |
| 2 |  | Interior of the distributor |   |  |              |

Do not put the distributor into operation until

- The service ports are mounted.
- The hoses are connected to the inlet connector, to the outlet connector, to the ventilation connector and to the cleaning port.

## 2.5 Warning and safety stickers

On the machine, there are a variety of warning and safety stickers (order number and description, → Spare parts list).

### **i** Notice

- Pay attention to the stickers on the machine.
- Keep the stickers in a legible condition and do not remove them.
- Replace any missing stickers.

Contact Service for orders.

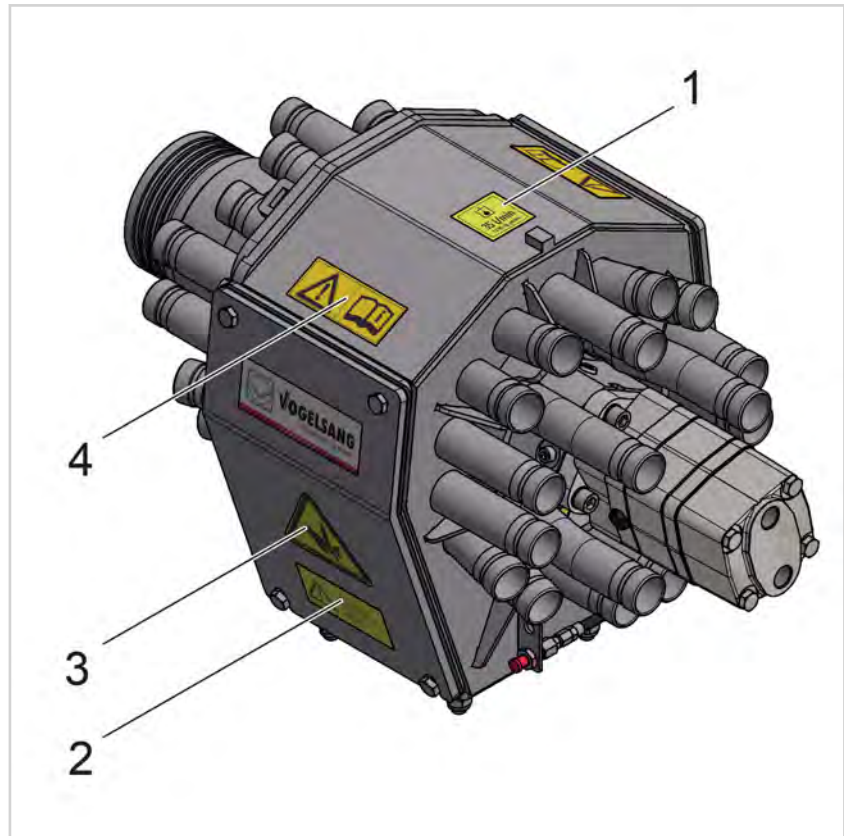

Fig. 2: Position of the warning and safety stickers

|   |         |   |         |
|---|---------|---|---------|
| 1 | VAU0398 | 3 | VAU.014 |
| 2 | VAU.013 | 4 | VAU.133 |





| Part    | Sticker | Description   |
|---------|---------|---|
| VAU0398 |         | Hydraulic oil volume flow                                     |
| VAU.013 |         | Caution!<br>Switch the drive off before opening.              |
| VAU.014 |         | Caution: risk of hand injuries!                               |
| VAU.133 |         | Before starting the machine, read the operating instructions. |

## 3 Product description

### 3.1 Overview

The overview shows the main parts and functional units of the distributor.

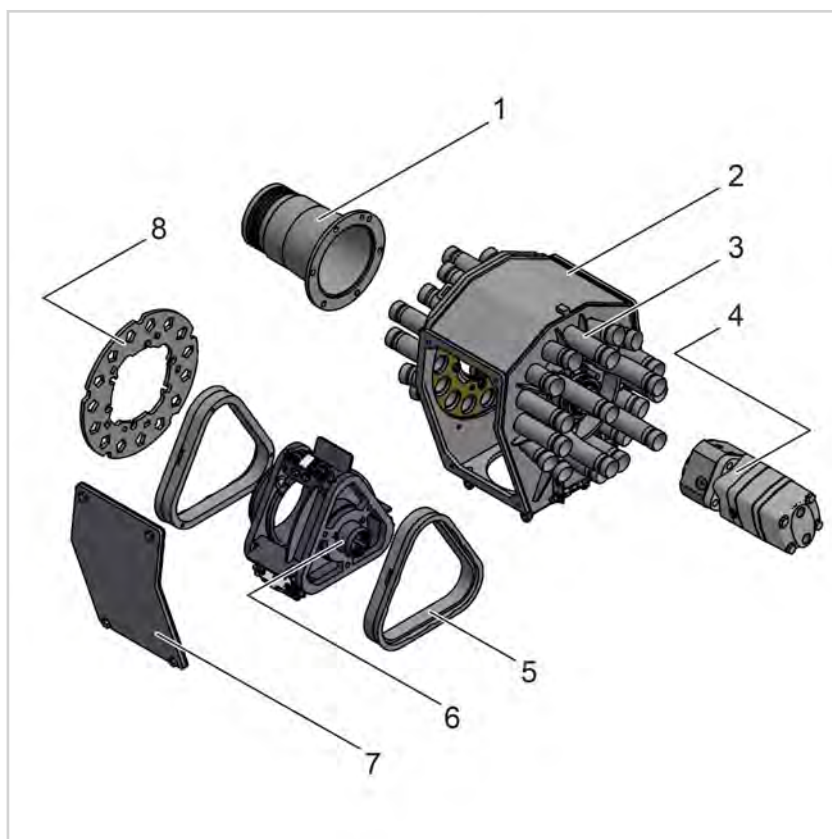

Fig. 3: Overview of ECQ parts

- |   |                                    |   |                                 |
|---|------------------------------------|---|---------------------------------|
| 1 | Inlet connector                    | 5 | Blade holder with cutting blade |
| 2 | Distributor housing                | 6 | Rotor                           |
| 3 | Outlet connector                   | 7 | Service port                    |
| 4 | Hydraulic motor with drive adapter | 8 | Cutting ring                    |

## 4 Specifications

### 4.1 Distributor

|                                |         |           |
|--------------------------------|---------|-----------|
| Inlet connector diameter       |         | DN 125    |
| Outlet connector diameter      |         | DN 40     |
| Number of outlet connectors    |         | 48        |
| Air intake                     |         | Four-fold |
| Dimension sheet no.            |         | MAS1016   |
| Weight                         | [kg]    | ca. 92    |
| Maximum internal pressure      | [bar]   | 2         |
| Permissible medium temperature | [°C]    | 0 to 45   |
| Noise emission                 | [dB(A)] | <70       |

### 4.2 Requirements for the vehicle hydraulics

|                      |          |
|----------------------|----------|
| Minimum volume flow: | 30 l/min |
| Maximum volume flow: | 40 l/min |



#### Notice

Spreader vehicles only reach their specified volume flow for hydraulic oil at their nominal motor speed. The larger the volume flow, the greater the insensitivity to foreign matter and fibrous matter.

---

### 4.3 Hydraulic motor

|  |                      |                |
|--|----------------------|----------------|
| Hydraulic motor  |                      | OMS<br>250     |
| Hydraulic motor part no.                                     |                      | AOM<br>0070    |
| Nominal displacement   | [cm <sup>3</sup> /U] | 250            |
| Shaft diameter   | [mm]                 | 32             |
| Max. rotational speed in continuous operation                | [rpm]                | 300            |
| Max. rotational speed in intermittent operation <sup>1</sup> | [rpm]                | 360            |
| Max. drop in pressure in continuous operation                | [bar]                | 200            |
| Max. drop in pressure in intermittent operation              | [bar]                | 250            |
| Max. drop in pressure at peak load <sup>2</sup>              | [bar]                | 270            |
| Max. torque in continuous operation                          | [Nm]                 | 720            |
| Max. torque in intermittent operation                        | [Nm]                 | 870            |
| Max. torque at peak load                                     | [Nm]                 | -              |
| <b>Optimum volume flow</b>                                   | <b>[l/min]</b>       | <b>30 - 40</b> |
| Max. volume flow in continuous operation                     | [l/min]              | 75             |
| Max. volume flow in intermittent operation                   | [l/min]              | 90             |
| Max. inlet pressure in continuous operation                  | [bar]                | 230            |
| Max. inlet pressure in intermittent operation                | [bar]                | 295            |
| Max. inlet pressure at peak load                             | [bar]                | 300            |

1) Intermittent operation: the permissible values may be reached max. 10 % every minute.

2) Peak load: the permissible values may be reached for max. 1 % of every minute.

|  |       |     |
|--|-------|-----|
| Max. return pressure with overflow oil line in continuous operation      | [bar] | 140 |
| Max. return pressure with overflow oil line in intermittent operation    | [bar] | 175 |
| Max. return pressure with overflow oil line at peak load                 | [bar] | 210 |
| Max. return pressure without overflow oil line in continuous operation   | [bar] | 50  |
| Max. return pressure without overflow oil line in intermittent operation | [bar] | 75  |

## 4.4 Hydraulic oil

### Temperature

|  |        |
|--|--------|
| Minimum ambient temperature                | -30 °C |
| Maximum ambient temperature                | 90 °C  |
| Minimum oil temperature (normal operation) | 30 °C  |
| Maximum oil temperature (normal operation) | 60 °C  |

### NOTICE!

If the oil temperature rises above 60 °C, it will considerably reduce the lifetime of the hydraulic oil.

### Viscosity

|   |                                 |
|---|---------------------------------|
| Minimum viscosity (operating temperature) | 20 mm <sup>2</sup> /s [100 SUS] |
| Maximum viscosity (operating temperature) | 75 mm <sup>2</sup> /s [370 SUS] |

We recommend using an oil grade with a viscosity of 35 mm<sup>2</sup>/s [165 SUS] at operating temperature.

The oil should have purity higher than 20/16 (ISO 4406).

We recommend mineral hydraulic oil with anti-wear additives, type HLP (DIN 51524) or HM (ISO 6743/4).

### **i** Notice

When adding oil, always use a filter.

## 4.5 Oil filter

Maximum permissible degree of contamination: 20/16  
(ISO 4406)

| System environment  | Recommended filters   |
|---|---|
| Normal contaminant load                                     | Return filter<br>40 µm absolute /<br>25 µm nominal (or finer)                     |
| High contaminant load<br>Complex systems<br>Closed circuits | Return filter<br>20 µm absolute /<br>10 µm nominal                                |
| Systems with quick latch couplings                          | Pressure filter directly before<br>the motor<br>40 µm absolute /<br>25 µm nominal |

## 4.6 Name plate

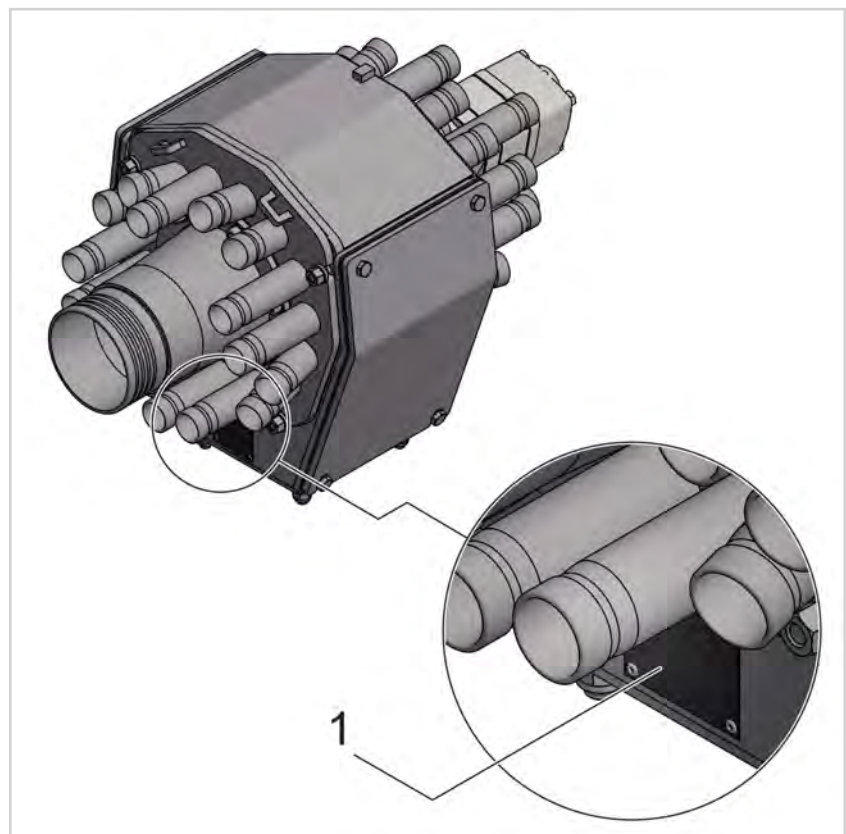
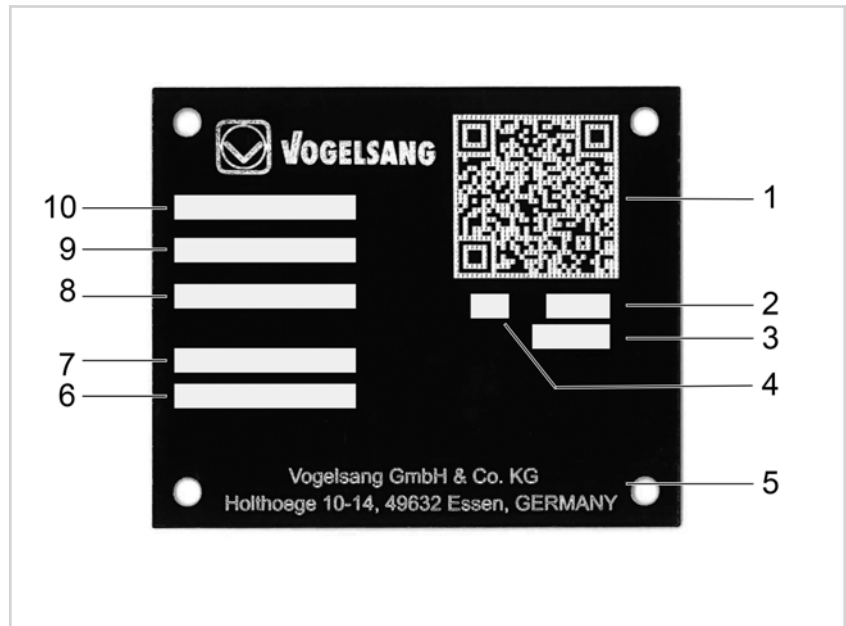

Fig. 4: Positioning of the nameplate

1 | Nameplate



The nameplate contains the following details:



- |   |   |    |                          |
|---|---|----|--------------------------|
| 1 | QR code with link to the Vogelsang web site | 6  | Other details (optional) |
| 2 | Year of manufacture                         | 7  | Part number              |
| 3 | Weight                                      | 8  | Serial number            |
| 4 | CE mark (optional)                          | 9  | Series (design)          |
| 5 | Vogelsang address                           | 10 | Product                  |

## 5 Storage

### NOTICE!

#### Damage to rubber parts

O-rings, gaskets and similar products can be rendered unusable by unfavourable storage conditions.

They could harden or soften, become permanently damaged or suffer surface damage.

- ▶ Observe the storage instructions.

---

No particular measures need to be taken in the case of short-term storage of up to four weeks.

The following conditions apply to long-term storage:

- The storage location must be dry (relative humidity below 65 %).
- The temperature of the storage location must be in the range between 5 °C and 30 °C.

If the distributor has already been put into operation, proceed as follows:

- ▶ Remove any foreign matter through the cleaning port.
- ▶ Clean the distributor by spreading water with it.
- ▶ Spray water into the air connectors while the distributor is running slowly. This keeps the air ducts in the interior of the distributor free.
- ▶ Clean, drain and dry the distributor with the maintenance ports and cleaning port open.
- ▶ Check the cutting components for wear.
- ▶ Lubricate the drive adapter after cleaning it via the grease nipple, using plenty of grease. This protects the seal faces of the sealing ring and displaces moisture.
- ▶ Spray or grease all the cutting surfaces with biodegradable oil.
- ▶ Turn the rotor with a mounting lever by at least one full revolution at least once every 3 months.

## 6 Transport

### 6.1 Safety notes

#### **WARNING!**

##### **Risk of crushing or concussion due to falling machine**

The centre of gravity of the machine could shift. When lifting, the machine could become unbalanced and fall down to one side.

- ▶ Before lifting the machine, note its centre of gravity. See, for example, the dimension drawing or the Transport chapter.
- ▶ Staying beneath lifted loads is prohibited. Have everyone leave the danger zone.
- ▶ Note and comply with the transport instructions.

---

##### **Note:**

- Only use suitable personnel for loading and transport, → *Personnel qualifications*.
- Pay attention to the weights and dimensions, → dimension sheet.
- Use only hoists designed for the weight of the units to be transported when lifting and moving heavy parts.
- Before lifting, note the machine's centre of gravity.
- During transportation, secure the machine from slipping, tilting and falling down.
- Use the specified slinging points.

## 6.2 Permissible transport options

### 6.2.1 Transporting the machine while suspended



- ▶ Position a crane with hoisting gear over the distributor.
- ▶ Place the slings (e. g. ropes or lifting straps) close to the distributor housing on both sides around the outlet connectors.
- ▶ Transport the distributor.

### 6.2.2 Transporting the machine on a Euro pallet

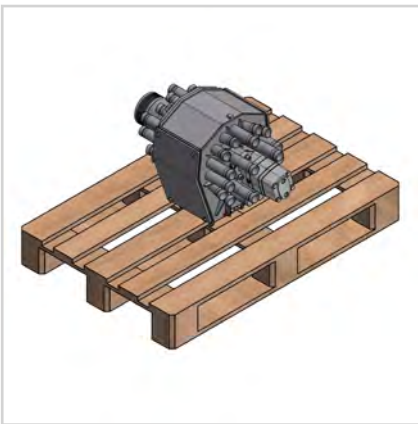

- ▶ Fasten the DosiMat on the pallet.
- ▶ Secure the DosiMat against slipping and tipping.
- ▶ Pick up the pallet and transport it.

## 7 Installation

### 7.1 Safety notes

#### **WARNING!**

##### **Risk of crushing or concussion due to falling machine**

The centre of gravity of the machine could shift. When lifting, the machine could become unbalanced and fall down to one side.

- ▶ Before lifting the machine, note its centre of gravity. See, for example, the dimension drawing or the Transport chapter.
  - ▶ Staying beneath lifted loads is prohibited. Have everyone leave the danger zone.
  - ▶ Note and comply with the transport instructions.
- 

#### **WARNING!**

##### **Risk of crushing or concussion due to falling DosiMat**

The DosiMat must not be held in position by means of the connected supply hose. That could cause bolt connections to break or fail. The DosiMat could fall.

- ▶ Securely screw the distributor to the spreader linkage or holder.
  - ▶ Check the screwed connections fastening the distributor in accordance with the maintenance plan to ensure they are firmly tightened. Tighten any loose screwed or bolted connections.
  - ▶ Wear protective clothing.
- 

#### **WARNING!**

##### **Beware the risk of injury from falling from high locations**

Some installation and maintenance work has to be done in higher locations. There is a risk of falling down.

- ▶ Use suitable equipment to climb up, e.g. a scaffold or ladder.
  - ▶ Make sure the scaffold or ladder is stable.
- 

##### **Note:**

- Use appropriate hoists to lift and move heavy parts.
- Use only hoists designed for the weight concerned.

## 7.2 Assembly instructions



### Notice

In the case of lubricated screws, bolts and threaded rods, the permissible tightening torque is reduced by 20 %.

| Thread | Property class                |      |      | Stain-<br>less<br>steel | Stain-<br>less<br>steel |
|--------|-------------------------------|------|------|-------------------------|-------------------------|
|        | 8.8                           | 10.9 | 12.9 | A2/A4<br>70             | A2/A4<br>80             |
|        | <b>Tightening torque [Nm]</b> |      |      |                         |                         |
| M6     | 10                            | 15   | 18   | 8                       | 10                      |
| M8     | 25                            | 35   | 40   | 20                      | 25                      |
| M10    | 50                            | 70   | 80   | 40                      | 50                      |
| M12    | 80                            | 120  | 140  | 60                      | 80                      |
| M14    | 135                           | 200  | 235  | 95                      | 135                     |
| M16    | 210                           | 310  | 360  | 160                     | 210                     |
| M20    | 425                           | 610  | 710  | 335                     | 425                     |
| M24    | 740                           | 1050 | 1230 | 565                     | 740                     |
| M30    | 1450                          | 2050 | 2450 | 1135                    | 1450                    |

Tab. 1: Tightening torques for screws, bolts and threaded rods

## 7.3 Mounting the DosiMat on the spreader vehicle

---

**i** When mounting, allow sufficient space for operation, maintenance, cleaning, and remedying of malfunctions, → 14.2 Dimension Drawing.

---

### Procedure

#### Warning!

**The cleaning port is clear. There is a risk of injury from the sharp-edged cutting blades inside the distributor.**

- ▶ Lift the distributor with a crane and position it on the spreader linkage.
- ▶ Align the distributor so that the boreholes in the mounting flange of the distributor are above the corresponding boreholes on the spreader linkage or holder.
- ▶ Seal the cleaning port with a flexible hose (DN 100, 1 m length).
- ▶ Fold back the hose and clamp it off.
- ▶ Tighten all screwed connections that fasten the distributor.



## 7.4 Connecting the hydraulics

### 7.4.1 Safety notes



#### Notice

The hydraulic connections for the machine must be carried out by qualified technical personnel.

---

#### **WARNING!**

##### **Risk of injury due to the failure of hydraulic parts if the maximum permissible hydraulic oil pressure is exceeded**

If the maximum permissible hydraulic oil pressure is exceeded, there is a risk of high pressure injection due to failure of hydraulic components.

- ▶ Observe the maximum permissible hydraulic oil pressure for the DosiMat: max. 200 bar.
  - ▶ Observe the maximum permissible hydraulic oil pressure for the hydraulic motor, → Specifications for the hydraulic motor.
  - ▶ Wear protective clothing.
- 

#### **WARNING!**

##### **Beware of skin and eye irritation and the risk of infection from contact with hydraulic oil**

Leaks may occur when coupling and uncoupling hydraulic lines or due to faulty seals. Leaking hydraulic oil can cause skin and eye irritation as well as infections.

- ▶ Have hydraulic lines connected by qualified personnel.
  - ▶ Wear the appropriate protective clothing.
  - ▶ In the event of injuries with hydraulic oil, see a doctor immediately!
-

**Note:**

- Only persons with special knowledge and experience in hydraulics may work on hydraulic equipment.
- Hydraulic and compressed air lines must be routed and installed correctly.
- Do not mix up connections.
- Valves, fittings, and the length and quality of the hoses must comply with the requirements.

## 7.4.2 Connecting hydraulic hoses

**Please note**

- Only use genuine hydraulic hoses supplied by the manufacturer.
- Before connecting hydraulic hoses, check that they are undamaged and clean.
- Check the date of manufacture of the hydraulic hoses. **Info** The date of manufacture can be found on the pressed part of the connection. The hydraulic hoses should not be older than 6 years, including a storage period of 2 years maximum.
- Depressurise the hydraulic system.
- Pay attention to cleanliness.
- Install the hydraulic hoses in such a way that under all operating conditions:
  - they are not under tension apart from the tension created by their own weight.
  - there is no compressive stress for short hoses.
  - the hydraulic hoses are not exposed to external, mechanical influences.
  - the hoses are prevented from chafing against other parts or against each other.  
If necessary, protect hydraulic hoses with protective covers and cover sharp-edged parts.
- The length of the hydraulic hoses must be selected so that over their entire range of movement:
  - the minimum permissible bending radius is not violated.
  - the hydraulic hoses are not put under tension.
- Secure hydraulic hoses at the specified mounting points.
- Painting hydraulic hoses is prohibited.

---

**i** Notice

We recommend installing pressure gauges in the hydraulic lines so that malfunctions can be detected and remedied at an early stage.

---

**Requirements for the hydraulic hoses:**

- Nominal diameter of at least DN 16
- Nominal pressure of at least PN 200

**Requirements for the overflow oil line:**

- Nominal diameter of at least DN 6

**Please note**

Maximum pressure in the return line: 15 bar

---

**i** Notice

The hydraulic connections for the machine must be carried out by qualified technical personnel.

---

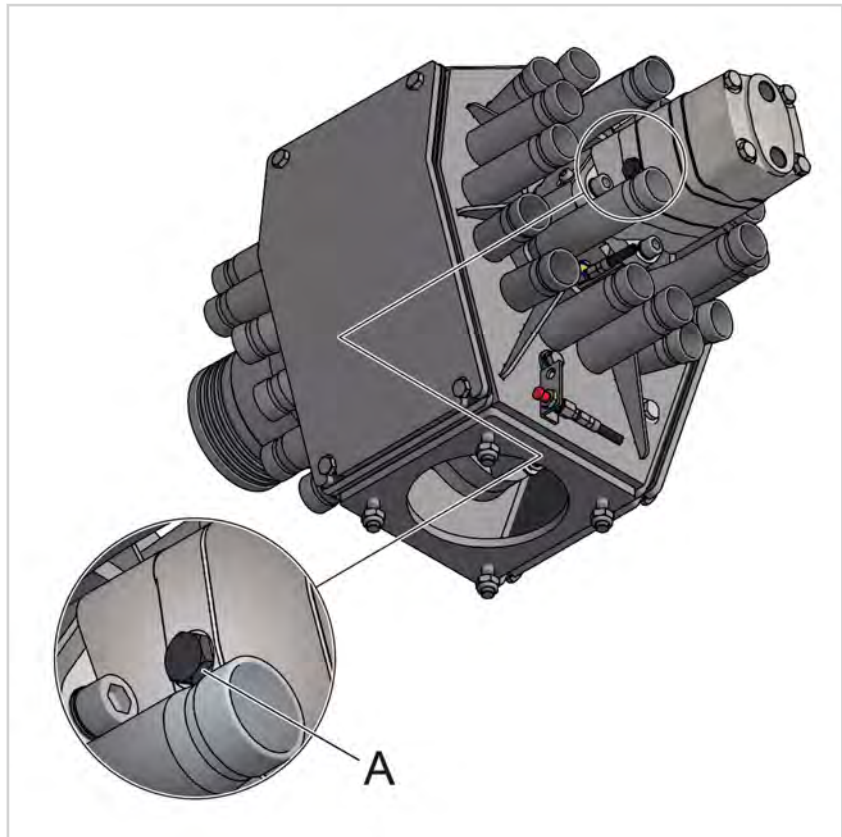
**Procedure**

- ▶ Connect the hydraulic hoses to the connectors of the hydraulic motor.
- ▶ Connect the hydraulic hoses to a double-acting hydraulic valve of the vehicle hydraulics.
- ▶ Connect a hydraulic hose (at least DN 6) to the overflow oil connector of the hydraulic motor (A).
- ▶ If two distributors are installed:
  - ▶ Connect the hydraulic motors of both distributors in series.
  - ▶ Connect the overflow oil line between the two distributors.

## 7.5 Reversing function

For the reversing function

- Connect the distributor to a double-acting hydraulic valve.
- install a time relay which switches over about once a minute, automatically sharpening the cutting blades.
- install a pressure gauge in the discharge line to the Dosi-Mat.

## 7.6 Installing sensors

### Qualified technical personnel

- ▶ Connect the speed sensor and the internal pressure sensor to the control, → *14.3 Data Sheet*.

## 7.7 Installing the supply hose

### NOTICE!

#### Risk of breakage due to excessive flange loads

Flange connections can exert excessive force on the machine. Risk of breakage.

- ▶ Mount the flanges with low stress.  
Maximum horizontal flange loads: 1275 N  
Maximum vertical flange loads: 1275 N  
Maximum bending moments: 350 Nm

#### Please note

The supply hose must be selected with a generous length.

- ▶ Mount the supply hose on the filling pipe using a hose clamp.



#### Notice

We recommend installing a pressure gauge in the supply line so that malfunctions can be detected and remedied at an early stage.

## 7.8 Mounting ventilation hoses

- ▶ Secure the ventilation hoses to the ventilation pipes using hose clamps.
- ▶ Shorten the hoses to a length of 1.5 m as far as possible.

## 7.9 Mounting the discharge hoses

---

**i** Notice  
When laying the hoses, avoid kinks, chafe points and sagging.

---

---

**i** Notice  
If the guidelines for connecting the discharge hoses are not observed, this can reduce the precision of the distribution.

---

**Please note**

- When laying hoses, follow the sequence outlined in the hose connection diagram.
- All hoses should be the same length.
- The hoses that go to the ground near the distributor should be laid in a large curve.

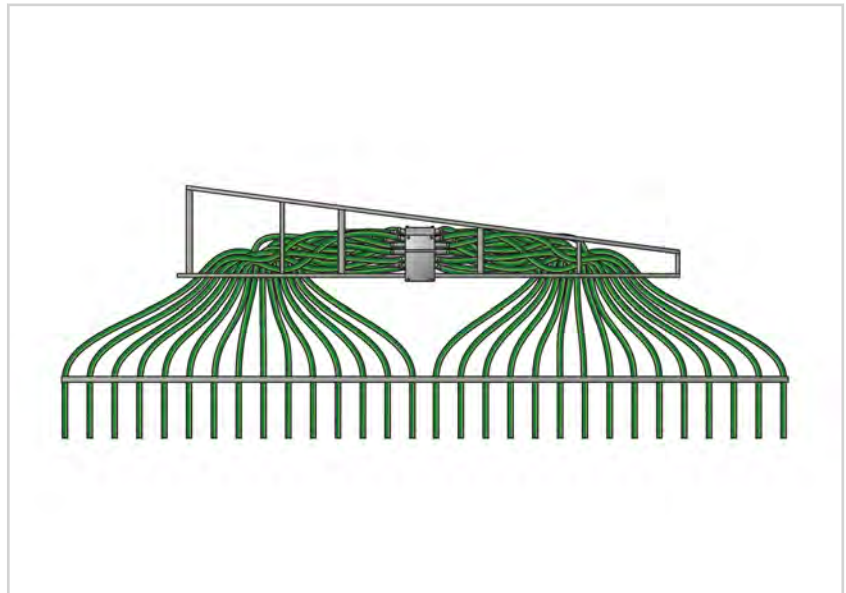

Fig. 5: Right boom hose layout diagram (example illustrated)

The left boom structure is a mirror image of this.

**Procedure**

- ▶ Route the discharge hoses from the distributor to the spreader linkage according to the hose connection diagram.
- ▶ Secure the discharge hoses to the outlet connector using hose clamps.

**i****Notice**

The hose connection diagram shown below only applies if the hoses are routed doubled and symmetrically according to the hose layout diagram. Hoses are counted in ascending order, from the middle of the linkage outwards in each case.

If a different hose installation is required, please contact Vogelsang-Service.

**7.9.1 Hose connection diagram**

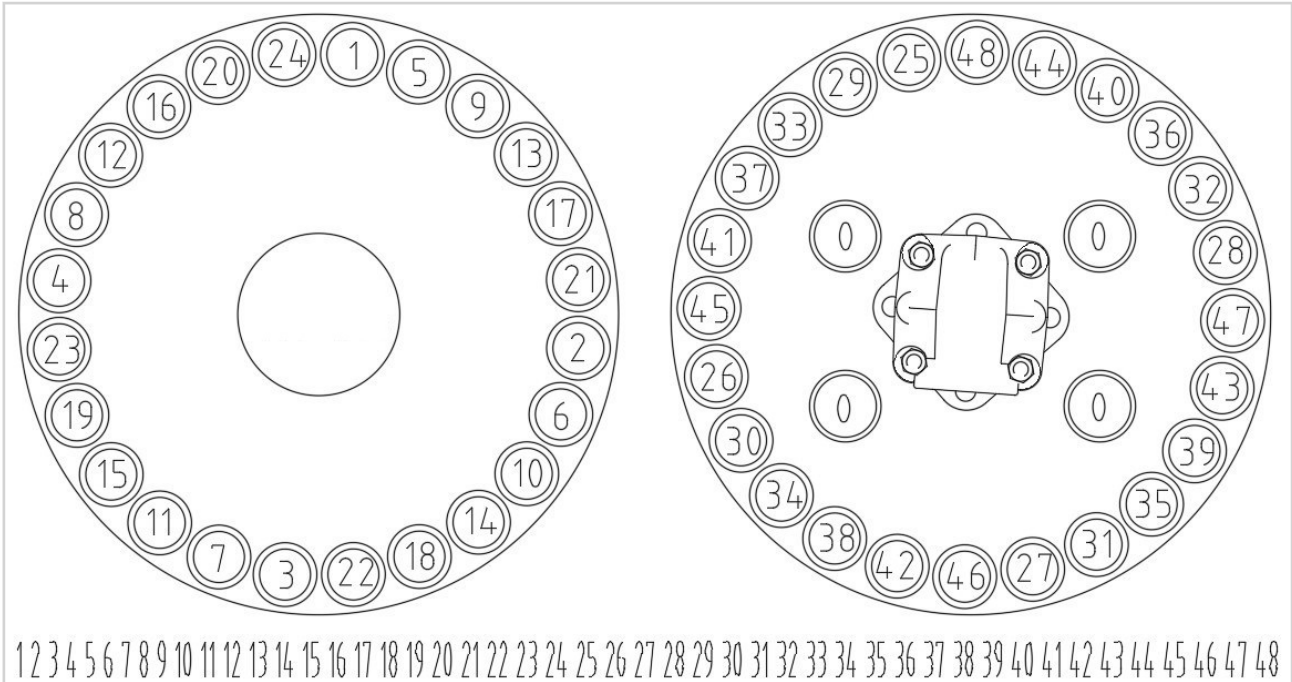

Fig. 6: Hose connection diagram ECQ48-40 right boom

0 | Ventilation

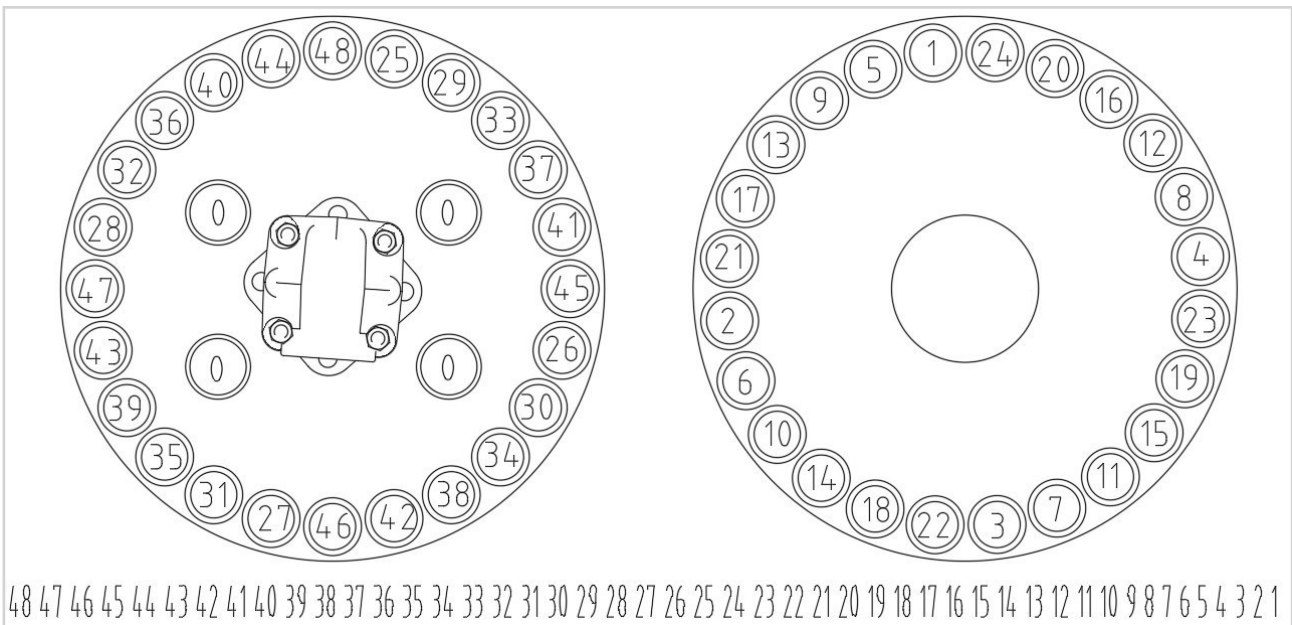

Fig. 7: Hose connection diagram ECQ48-40 left boom

0 | Ventilation



## 8 Start-up

### 8.1 Safety notes

- Only start the machine up
  - if all protective and safety devices are functional.
  - if access to the danger areas is not possible.



#### Notice

The machine must be started up by qualified technical personnel.

---

#### **WARNING!**

##### **Beware the risk of injury from falling from high locations**

Some installation and maintenance work has to be done in higher locations. There is a risk of falling down.

- ▶ Use suitable equipment to climb up, e.g. a scaffold or ladder.
  - ▶ Make sure the scaffold or ladder is stable.
- 

#### **WARNING!**

##### **Risk of cutting on sharp-edged parts**

If the rotor can be freely accessed, there is a risk of cutting on the sharp edges of the cutting components.

- ▶ Operate the distributor only if the supply hose, the discharge hoses and the foreign matter hose are connected.
  - ▶ Only operate the distributor if the maintenance port is mounted and screwed on.
  - ▶ Before dismounting the maintenance port, switch the hydraulic valve to "floating position".
  - ▶ Switch off the engine of the tractor or spreader vehicle.
  - ▶ Before installation, maintenance and repair work, secure moving parts so that they cannot move.
  - ▶ Wear protective clothing.
-

**⚠ WARNING!****Risk of cutting on sharp-edged parts during functional test**

If the rotor can be freely accessed, there is a risk of cutting on the sharp edges of the cutting components.

- ▶ A functional test (e.g. to check the safety device or the rotational action of the rotor) may only be carried out by qualified technical personnel.
  - ▶ Before switching on the machine for functional tests, make sure that there are no persons in the danger area.
  - ▶ Wear protective clothing.
- 

**⚠ WARNING!****Danger from bursting distributor housing**

If the maximum permissible internal pressure is exceeded, the DosiMat housing may burst. This may result in injuries.

- ▶ Be sure to observe the maximum permissible internal pressure of the DosiMat: 2 bar.
- 

**⚠ WARNING!****Risk of injury due to the failure of hydraulic parts if the maximum permissible hydraulic oil pressure is exceeded**

If the maximum permissible hydraulic oil pressure is exceeded, there is a risk of high pressure injection due to failure of hydraulic components.

- ▶ Observe the maximum permissible hydraulic oil pressure for the DosiMat: max. 200 bar.
  - ▶ Observe the maximum permissible hydraulic oil pressure for the hydraulic motor, → Specifications for the hydraulic motor.
  - ▶ Wear protective clothing.
-

**⚠ WARNING!****Risk of injury due to the liquid manure supply hose bursting**

If the maximum permissible pressure in the liquid manure supply hose is exceeded, the hose can burst and the medium can splash out. This may result in injuries.

- ▶ Note the maximum permissible pressure in the liquid manure supply hose: 2 bar.
- ▶ Wear protective clothing.

**⚠ WARNING!****Beware of skin and eye irritation and the risk of infection from contact with hydraulic oil**

Leaks may occur when coupling and uncoupling hydraulic lines or due to faulty seals. Leaking hydraulic oil can cause skin and eye irritation as well as infections.

- ▶ Have hydraulic lines connected by qualified personnel.
- ▶ Wear the appropriate protective clothing.
- ▶ In the event of injuries with hydraulic oil, see a doctor immediately!

**i****Notice**

In order to achieve good average distribution, a pressure in the distributor of  $\geq 0.3$  bar is required. When using low-viscosity media, you achieve better average distribution with a higher throughput.

## 8.2 Start-up sequence

1. Work through the checklist, → 8.3 Checklist.
2. Start the hydraulic system, → 8.4 Starting the hydraulic system.
3. Start the DosiMat.

## 8.3 Checklist

### Installation on the linkage or spreader device

- The distributor is firmly bolted to the linkage or spreader device.

### Hydraulic drive

- There is no air in the system.
- The hydraulic motor is bolted firmly in place.
- The mounting flanges on the hydraulic motor and its counterpart are in full contact.
- The hydraulic motor is connected correctly.
- The hydraulic oil tank is filled with oil up to the upper mark.

### Sensors

- The sensors are connected to the control.

### Hose system

- The foreign matter hoses is connected and clamped off.
- The supply hose is connected.
- The ventilation hoses are connected.
- The discharge hoses are connected.
- The hose clamps are firmly in place.
- There is free flow through the hoses.
- Good average distribution is provided.

## 8.4 Starting the hydraulic system

- ▶ Fill the oil tank with hydraulic oil up to the upper level mark through a fine filter.
- ▶ Start the hydraulic motor and run it briefly at the lowest speed.
- ▶ If the hydraulic motor is fitted with a vent screw, leave the screw open until oil emerges free of bubbles.
- ▶ Close the vent screw.

## 9 Operation

### 9.1 Safety notes

#### **WARNING!**

##### **Risk of cutting on sharp-edged parts**

If the rotor can be freely accessed, there is a risk of cutting on the sharp edges of the cutting components.

- ▶ Operate the distributor only if the supply hose, the discharge hoses and the foreign matter hose are connected.
  - ▶ Only operate the distributor if the maintenance port is mounted and screwed on.
  - ▶ Before dismounting the maintenance port, switch the hydraulic valve to "floating position".
  - ▶ Switch off the engine of the tractor or spreader vehicle.
  - ▶ Before installation, maintenance and repair work, secure moving parts so that they cannot move.
  - ▶ Wear protective clothing.
- 

#### **WARNING!**

##### **Skin and eye irritations as well as risk of infection due to contact with working materials or the medium**

All work on the machine can lead to contact with working materials or media. Contact may cause skin or eye irritation.

- ▶ Inform staff about hazardous substances.
  - ▶ Wear protective clothing.
  - ▶ Before working on the machine, depressurize it to prevent lubricants and media from squirting out.
- 

#### **WARNING!**

##### **Danger from bursting distributor housing**

If the maximum permissible internal pressure is exceeded, the DosiMat housing may burst. This may result in injuries.

- ▶ Be sure to observe the maximum permissible internal pressure of the DosiMat: 2 bar.
-

**⚠ WARNING!****Risk of injury due to the failure of hydraulic parts if the maximum permissible hydraulic oil pressure is exceeded**

If the maximum permissible hydraulic oil pressure is exceeded, there is a risk of high pressure injection due to failure of hydraulic components.

- ▶ Observe the maximum permissible hydraulic oil pressure for the DosiMat: max. 200 bar.
- ▶ Observe the maximum permissible hydraulic oil pressure for the hydraulic motor, → Specifications for the hydraulic motor.
- ▶ Wear protective clothing.

**⚠ WARNING!****Risk of injury due to the liquid manure supply hose bursting**

If the maximum permissible pressure in the liquid manure supply hose is exceeded, the hose can burst and the medium can splash out. This may result in injuries.

- ▶ Note the maximum permissible pressure in the liquid manure supply hose: 2 bar.
- ▶ Wear protective clothing.

**⚠ WARNING!****Beware of skin and eye irritation and the risk of infection from contact with hydraulic oil**

Leaks may occur when coupling and uncoupling hydraulic lines or due to faulty seals. Leaking hydraulic oil can cause skin and eye irritation as well as infections.

- ▶ Have hydraulic lines connected by qualified personnel.
- ▶ Wear the appropriate protective clothing.
- ▶ In the event of injuries with hydraulic oil, see a doctor immediately!

**⚠ CAUTION!****Beware of the risk of burns due to exposed hot surfaces**

During operation the hydraulic oil can reach a temperature of more than 60 °C.

The hydraulic motor reaches high temperatures in normal operation.

The DosiMat housing can become very hot during dry running of the cutting blades.

- ▶ Avoid contact with hot surfaces.
- ▶ Avoid dry running of the cutting blades.
- ▶ Operate the DosiMat only when it is filled with the medium to be distributed.
- ▶ Allow the DosiMat to cool down to ambient temperature before starting maintenance and repair work.
- ▶ Wear protective clothing.

**Note:**

- Before starting work, familiarise yourself with all of the machine's equipment, controls and functions.
- Only operate the machine
  - if all protective and safety devices are functional.
  - if access to the danger areas is not possible.
- Do not work in any way that could pose a risk to safety.

## 9.2 Operating instructions

**NOTICE!****Avoiding dry running of the DosiMat**

Prolonged dry running of the DosiMat can result in increased wear.

- ▶ Limit dry running of the DosiMat to 30 seconds at the most.

**NOTICE!****Preventing foreign matter from entering the DosiMat**

Stones, metal parts and other foreign matter that cannot be cut can result in increased wear and hinder smooth operation if they enter the DosiMat.

- ▶ Prevent foreign matter that cannot be cut from entering the DosiMat.

---

**i Notice**

In order to achieve good average distribution, a pressure in the distributor of  $\geq 0.3$  bar is required. When using low-viscosity media, you achieve better average distribution with a higher throughput.

---



## 9.3 Reverse

For the reversing function, the DosiMat must be connected to a double-acting hydraulic valve.

The reversing function (reversal of rotation):

- can be used to rectify almost all malfunctions caused by foreign matter and high fibre content in the medium.
- results in optimum self-sharpening of the cutting blades.

To achieve a high level of operational safety and trouble-free operation:

- reverse at least in every headland.
- install a time relay which switches over about once a minute, automatically sharpening the cutting blades.
- install a pressure gauge in the discharge line to the DosiMat. This allows malfunctions to be detected at an early stage and corrected by reversing.

### NOTICE!

#### Hydraulic valve with "lock position"

To prevent damage in the hydraulic system, never set the hydraulic valve to "lock position" when the rotor is rotating at high speed. Reduce the speed of the rotor before the switch-off.

- ▶ The hydraulic valve should always have an intermediate setting with "floating position". A valve with "lock position" is not recommended.

## 10 Maintenance

### 10.1 Lubricants

| <b>Renolit GP 2</b>       |   |                          |
|---------------------------|---|--------------------------|
| Part number               | BSS.008                                     |                          |
| Description               | Lithium soap grease with a mineral oil base |                          |
| <b>Characteristics</b>    |   | <b>Test according to</b> |
| Identification            | K2K-30<br>ISO-L-X-CCEA 2                    | DIN 51502<br>ISO 6743-9  |
| Intrinsic viscosity       |   | DIN 51562-1              |
| At 40 °C                  | 110 mm <sup>2</sup> /s                      |                          |
| At 100 °C                 | 9.5 mm <sup>2</sup> /s                      |                          |
| Dropping point            | ≥ 180 °C                                    | IP 396                   |
| Temperature range for use | -30 °C - +120 °C                            | DIN 51825                |

## 10.2 Tightening torques



### Notice

In the case of lubricated screws, bolts and threaded rods, the permissible tightening torque is reduced by 20 %.

| Thread | Property class                |      |      | Stain-<br>less<br>steel | Stain-<br>less<br>steel |
|--------|-------------------------------|------|------|-------------------------|-------------------------|
|        | 8.8                           | 10.9 | 12.9 | A2/A4<br>70             | A2/A4<br>80             |
|        | <b>Tightening torque [Nm]</b> |      |      |                         |                         |
| M6     | 10                            | 15   | 18   | 8                       | 10                      |
| M8     | 25                            | 35   | 40   | 20                      | 25                      |
| M10    | 50                            | 70   | 80   | 40                      | 50                      |
| M12    | 80                            | 120  | 140  | 60                      | 80                      |
| M14    | 135                           | 200  | 235  | 95                      | 135                     |
| M16    | 210                           | 310  | 360  | 160                     | 210                     |
| M20    | 425                           | 610  | 710  | 335                     | 425                     |
| M24    | 740                           | 1050 | 1230 | 565                     | 740                     |
| M30    | 1450                          | 2050 | 2450 | 1135                    | 1450                    |

Tab. 2: Tightening torques for screws, bolts and threaded rods

## 10.3 Spare parts

Contact Service for order-specific spare parts lists and spare parts orders.

- ▶ Have the serial number of the machine ready.

Refer to the name plate for the serial number, → 4.6 *Name plate*.

## 10.4 Maintenance intervals

---

### **i** Notice

The maintenance intervals depend on the amount of wear and the proportion of foreign matter.  
 The inspection intervals may be shortened according to the results.

---

### 10.4.1 Before start-up

| Part   | Maintenance task   |
|--|--|
| Hydraulic motor  | <ul style="list-style-type: none"> <li>▶ Check that the nuts on the hydraulic motor are firmly in place.</li> <li>▶ Tighten any loose nuts.</li> </ul>   |
| Hose clamps of the discharge hoses and the ventilation hoses | <ul style="list-style-type: none"> <li>▶ Check that the hose clamps are securely in place on the discharge hoses and the ventilation hoses.</li> <li>▶ If any hose clamps are loose, tighten the adjusting screw.</li> </ul> |
| Hose clamps on the supply hose                               | <ul style="list-style-type: none"> <li>▶ Check that the hose clamps are securely in place on the supply hose.</li> <li>▶ If any hose clamps are loose, tighten the adjusting screw.</li> </ul>                               |

### 10.4.2 After the first 20 operating hours

| Part   | Maintenance task   |
|--|--|
| Machine mounting   | <ul style="list-style-type: none"> <li>▶ Check that the screwed and bolted connections fastening the machine are tight.</li> <li>▶ Tighten any loose screwed or bolted connections.</li> </ul>                               |
| Hydraulic motor  | <ul style="list-style-type: none"> <li>▶ Check that the nuts on the hydraulic motor are firmly in place.</li> <li>▶ Tighten any loose nuts.</li> </ul>   |
| Hose clamps of the discharge hoses and the ventilation hoses | <ul style="list-style-type: none"> <li>▶ Check that the hose clamps are securely in place on the discharge hoses and the ventilation hoses.</li> <li>▶ If any hose clamps are loose, tighten the adjusting screw.</li> </ul> |
| Hose clamps on the supply hose                               | <ul style="list-style-type: none"> <li>▶ Check that the hose clamps are securely in place on the supply hose.</li> <li>▶ If any hose clamps are loose, tighten the adjusting screw.</li> </ul>                               |

### 10.4.3 Every 50 operating hours

| Part                                      | Maintenance task   |
|---|--|
| Distributor housing                       | <ul style="list-style-type: none"> <li>▶ Remove foreign matter from the foreign matter hoses and the distributor housing.</li> <li>▶ Clean the distributor.</li> <li>▶ Clean the air duct connections via the ventilation hoses.</li> </ul>                        |
| Cutting blades, cutting rings and gaskets | <ul style="list-style-type: none"> <li>▶ Check the cutting blades, the cutting rings and the gaskets for wear.</li> <li>▶ Replace worn cutting blades, cutting rings and gaskets.</li> </ul>   |
| Eccentric adjuster                        | <ul style="list-style-type: none"> <li>▶ Check the preload of the cutting blades.</li> <li>▶ If the preload is too low, remove the eccentric adjuster and make it operable.</li> </ul>   |
| Drive adapter                             | <ul style="list-style-type: none"> <li>▶ Check the drive adapter for leaks.</li> <li>▶ If medium is leaking out, replace the gaskets on the distributor.</li> <li>▶ If oil is leaking out, replace the hydraulic motor (qualified technical personnel).</li> </ul> |
| Drive adapter                             | <ul style="list-style-type: none"> <li>▶ Lubricate the drive adapter via the grease nipple.</li> </ul>   |
| Hydraulic oil tank                        | <ul style="list-style-type: none"> <li>▶ Check the oil level.</li> <li>▶ Top up oil as needed.</li> </ul>  |
| Hydraulic oil tank                        | <ul style="list-style-type: none"> <li>▶ Check the hydraulic oil for contamination.</li> <li>▶ If the oil is contaminated, change it and dispose of it in an environmentally friendly manner.</li> </ul>   |
| Hydraulic oil filter                      | <ul style="list-style-type: none"> <li>▶ Check the oil filter for contamination.</li> <li>▶ If the oil filter is contaminated, replace it.</li> </ul>  |
| Hydraulic system                          | <p><b>Qualified technical personnel</b></p> <ul style="list-style-type: none"> <li>▶ Check the hydraulic system for leaks.</li> <li>▶ Replace any leaking parts.</li> </ul>  |

#### 10.4.4 Every 2000 operating hours, at least every 12 months

| Part   | Maintenance task  |
|--|---|
| Machine mounting   | <ul style="list-style-type: none"> <li>▶ Check that the screwed and bolted connections fastening the machine are tight.</li> <li>▶ Tighten any loose screwed or bolted connections.</li> </ul>  |
| Hose clamps of the discharge hoses and the ventilation hoses | <ul style="list-style-type: none"> <li>▶ Check that the hose clamps are securely in place on the discharge hoses and the ventilation hoses.</li> <li>▶ If any hose clamps are loose, tighten the adjusting screw.</li> </ul>  |
| Hose clamps on the supply hose                               | <ul style="list-style-type: none"> <li>▶ Check that the hose clamps are securely in place on the supply hose.</li> <li>▶ If any hose clamps are loose, tighten the adjusting screw.</li> </ul>  |
| Hydraulic hoses and fittings                                 | <p><b>Qualified technical personnel</b></p> <ul style="list-style-type: none"> <li>▶ Check that the hydraulic hoses and fittings are in safe working condition.</li> <li>▶ If any hydraulic hoses or fittings are not in safe working condition, replace them.</li> </ul> |

#### 10.4.5 Every 6 years

| Part            | Maintenance task   |
|-----------------|--|
| Hydraulic hoses | <p><b>Qualified technical personnel</b></p> <ul style="list-style-type: none"> <li>▶ Replace the hydraulic hoses.</li> </ul> |

### 10.4.6 Before longer periods of shutdown

| Part                                      | Maintenance task  |
|---|---|
| Distributor housing                       | <ul style="list-style-type: none"> <li>▶ Remove foreign matter from the foreign matter hoses and the distributor housing.</li> <li>▶ Clean the distributor.</li> <li>▶ Clean the air duct connections via the ventilation hoses.</li> </ul> |
| Cutting blades, cutting rings and gaskets | <ul style="list-style-type: none"> <li>▶ Check the cutting blades, the cutting rings and the gaskets for wear.</li> <li>▶ Replace worn cutting blades, cutting rings and gaskets.</li> </ul>  |
| Cutting rings                             | <ul style="list-style-type: none"> <li>▶ Spray the cutting rings with biodegradable oil or grease them.</li> </ul>  |
| Drive adapter                             | <ul style="list-style-type: none"> <li>▶ Lubricate the drive adapter via the grease nipple.</li> </ul>  |
| Eccentric adjuster                        | <ul style="list-style-type: none"> <li>▶ Check the movability of the eccentrics.</li> <li>▶ Remove eccentrics that do not move and make sure they can move.</li> </ul>  |

### 10.4.7 After long periods of shutdown

| Part            | Maintenance task   |
|-----------------|--|
| Hydraulic motor | <ul style="list-style-type: none"> <li>▶ Check that the nuts on the hydraulic motor are firmly in place.</li> <li>▶ Tighten any loose nuts.</li> </ul>   |
| Drive adapter   | <ul style="list-style-type: none"> <li>▶ Check the drive adapter for leaks.</li> <li>▶ If medium is leaking out, replace the gaskets on the distributor.</li> <li>▶ If oil is leaking out, replace the hydraulic motor (qualified technical personnel).</li> </ul> |



## 10.5 Maintenance tasks

**Note:**

- Do the specified maintenance work punctually.
- Switch off the machine before doing any maintenance or repair work.
- Use only genuine spare parts or parts approved by Vogel-sang.
- Install spare parts correctly.
- Once the work has been completed, install and check any removed safety devices.



**Notice**

Treat cleaning agents, solvents and lubricants as haz-ardous waste and dispose of them properly.

---



**Notice**

For guarantee reasons, all of the maintenance work done must be documented in the service plan → 14.4 *Service plan*

---

## 10.5.1 Safety notes

### **WARNING!**

#### **Beware the risk of injury from falling from high locations**

Some installation and maintenance work has to be done in higher locations. There is a risk of falling down.

- ▶ Use suitable equipment to climb up, e.g. a scaffold or ladder.
  - ▶ Make sure the scaffold or ladder is stable.
- 

### **WARNING!**

#### **Risk of cutting on sharp-edged parts**

If the rotor can be freely accessed, there is a risk of cutting on the sharp edges of the cutting components.

- ▶ Operate the distributor only if the supply hose, the discharge hoses and the foreign matter hose are connected.
  - ▶ Only operate the distributor if the maintenance port is mounted and screwed on.
  - ▶ Before dismounting the maintenance port, switch the hydraulic valve to "floating position".
  - ▶ Switch off the engine of the tractor or spreader vehicle.
  - ▶ Before installation, maintenance and repair work, secure moving parts so that they cannot move.
  - ▶ Wear protective clothing.
- 

### **WARNING!**

#### **Risk of crushing or concussion due to falling DosiMat**

The DosiMat must not be held in position by means of the connected supply hose. That could cause bolt connections to break or fail. The DosiMat could fall.

- ▶ Securely screw the distributor to the spreader linkage or holder.
  - ▶ Check the screwed connections fastening the distributor in accordance with the maintenance plan to ensure they are firmly tightened. Tighten any loose screwed or bolted connections.
  - ▶ Wear protective clothing.
-

**⚠ WARNING!****Danger from bursting distributor housing**

If the maximum permissible internal pressure is exceeded, the DosiMat housing may burst. This may result in injuries.

- ▶ Be sure to observe the maximum permissible internal pressure of the DosiMat: 2 bar.
- 

**⚠ WARNING!****Risk of injury due to the liquid manure supply hose bursting**

If the maximum permissible pressure in the liquid manure supply hose is exceeded, the hose can burst and the medium can splash out. This may result in injuries.

- ▶ Note the maximum permissible pressure in the liquid manure supply hose: 2 bar.
  - ▶ Wear protective clothing.
- 

**⚠ WARNING!****Skin and eye irritations as well as risk of infection due to contact with working materials or the medium**

All work on the machine can lead to contact with working materials or media. Contact may cause skin or eye irritation.

- ▶ Inform staff about hazardous substances.
  - ▶ Wear protective clothing.
  - ▶ Before working on the machine, depressurize it to prevent lubricants and media from squirting out.
-

### CAUTION!

#### **Beware of the risk of burns due to exposed hot surfaces**

During operation the hydraulic oil can reach a temperature of more than 60 °C.

The hydraulic motor reaches high temperatures in normal operation.

The DosiMat housing can become very hot during dry running of the cutting blades.

- ▶ Avoid contact with hot surfaces.
- ▶ Avoid dry running of the cutting blades.
- ▶ Operate the DosiMat only when it is filled with the medium to be distributed.
- ▶ Allow the DosiMat to cool down to ambient temperature before starting maintenance and repair work.
- ▶ Wear protective clothing.

### CAUTION!

#### **Scalding or burning by hot medium**

Contact with hot media or working materials over 60 °C can cause scalding or burns.

- ▶ Avoid contact with hot media and working materials.
- ▶ Before maintenance and repair work, flush out the DosiMat and release the pressure.
- ▶ Wear protective clothing.

## 10.5.2 Switching off the distributor

|                    |  |
|--------------------|--|
| <b>Information</b> | <p>The distributor must be switched off in order to carry out work on the distributor, e. g.</p> <ul style="list-style-type: none"> <li>• Cleaning the distributor</li> <li>• Replacing wear parts</li> <li>• Replacing gaskets</li> </ul> |
|--------------------|--|

#### **Procedure**

- ▶ Set the hydraulic valve to "floating position".
- ▶ Switch off the motor of the spreader vehicle and secure it to prevent it from being switched on again.

**NOTICE!**

Both hydraulic hoses at the distributor must be depressurised.

**10.5.3 Dismounting the service port****Information**

The service port must be dismounted in order to carry out work on the distributor, e. g.

- Cleaning the distributor
- Replacing wear parts
- Replacing gaskets

**Preparatory activities**

- ▶ Switch off the distributor, → *10.5.2 Switching off the distributor.*

**Procedure**

- ▶ Unscrew the hexagon head bolts on the service port (1).
- ▶ Remove the service port and the flat gasket (2).

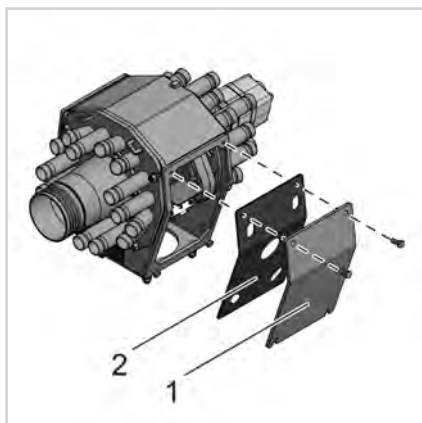

## 10.5.4 Installing the service port

### Information

The service port must be reinstalled on the distributor after completing the work.

### Procedure

- ▶ Place the flat gasket (2) and the service port (1) on the housing.

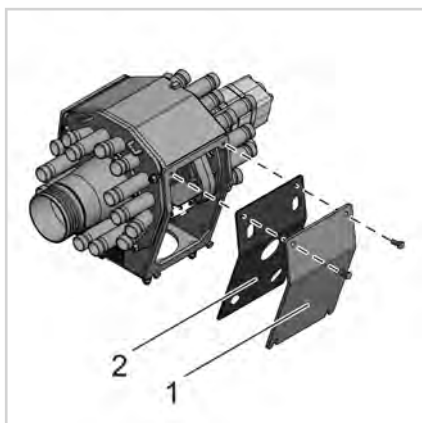

**Attention!** Make sure the flat gasket (2) and service port (1) are in the correct position.

- ▶ Screw in the hexagon head bolts and tighten them.

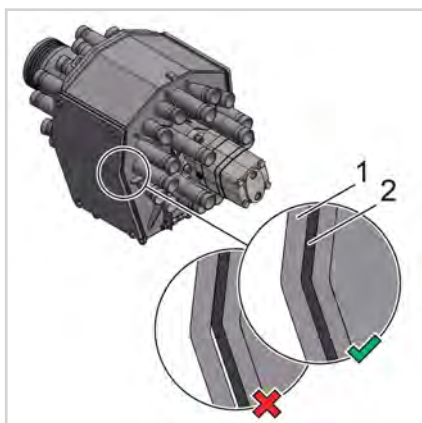

## 10.5.5 Tightening screw and bolt connections



### Notice

In the case of lubricated screws, bolts and threaded rods, the permissible tightening torque is reduced by 20 %.

| Thread | Property class                |      |      | Stain-<br>less<br>steel | Stain-<br>less<br>steel |
|--------|-------------------------------|------|------|-------------------------|-------------------------|
|        | 8.8                           | 10.9 | 12.9 | A2/A4<br>70             | A2/A4<br>80             |
|        | <b>Tightening torque [Nm]</b> |      |      |                         |                         |
| M6     | 10                            | 15   | 18   | 8                       | 10                      |
| M8     | 25                            | 35   | 40   | 20                      | 25                      |
| M10    | 50                            | 70   | 80   | 40                      | 50                      |
| M12    | 80                            | 120  | 140  | 60                      | 80                      |
| M14    | 135                           | 200  | 235  | 95                      | 135                     |
| M16    | 210                           | 310  | 360  | 160                     | 210                     |
| M20    | 425                           | 610  | 710  | 335                     | 425                     |
| M24    | 740                           | 1050 | 1230 | 565                     | 740                     |
| M30    | 1450                          | 2050 | 2450 | 1135                    | 1450                    |

Tab. 3: Tightening torques for screws, bolts and threaded rods

| Part     | Entire machine   |
|----------|--|
| Interval | <ul style="list-style-type: none"> <li>• After the first 20 operating hours</li> <li>• Every 2000 operating hours, at least every 12 months</li> </ul> |

**Procedure**

- ▶ Check that all screwed and bolted connections are tight.
- ▶ Tighten any loose screwed or bolted connections.



### 10.5.6 Tightening the nuts on the hydraulic motor

|                 |  |
|-----------------|--|
| <b>Part</b>     | Hydraulic motor  |
| <b>Interval</b> | <ul style="list-style-type: none"><li>• Before start-up</li><li>• After the first 20 operating hours</li><li>• After long shutdown periods</li></ul> |

#### Preparatory activities

- ▶ Switch off the distributor, → *10.5.2 Switching off the distributor.*

#### Procedure

- ▶ Check that the screw connections on the hydraulic motor are tight.
- ▶ Tighten any loose screwed connections with 95 Nm.

### 10.5.7 Cleaning the DosiMat

|                 |  |
|-----------------|--|
| <b>Part</b>     | Distributor housing  |
| <b>Interval</b> | <ul style="list-style-type: none"> <li>• Every 50 operating hours</li> <li>• Before long periods of shut-down</li> </ul> |

#### Preparatory activities

- ▶ Switch off the distributor, → *10.5.2 Switching off the distributor.*

#### Procedure

- ▶ Empty the distributor.
  - ▶ Place a collecting container under the foreign matter hose.
  - ▶ Release the hose clamp on the foreign matter hose.
  - ▶ Collect the medium and foreign matter in the collecting container and dispose of them in an environmentally friendly manner.
- ▶ Dismount the service port, → *10.5.3 Dismounting the service port.*
- ▶ Clean the distributor housing with water.
- ▶ Clean the air ducts above the ventilation hoses with water.

#### Concluding activities

- ▶ Install the service port, → *10.5.4 Installing the service port.*
- ▶ Fold up the foreign matter hose and close it with the hose clamp.

## 10.5.8 Replacing wear parts

### Disassembly

#### **WARNING!**

#### Risk of cutting on sharp-edged parts

If the rotor can be freely accessed, there is a risk of cutting on the sharp edges of the cutting components.

- ▶ Operate the distributor only if the supply hose, the discharge hoses and the foreign matter hose are connected.
- ▶ Only operate the distributor if the maintenance port is mounted and screwed on.
- ▶ Before dismounting the maintenance port, switch the hydraulic valve to "floating position".
- ▶ Switch off the engine of the tractor or spreader vehicle.
- ▶ Before installation, maintenance and repair work, secure moving parts so that they cannot move.
- ▶ Wear protective clothing.

| Part                          | Rotor unit   |
|-------------------------------|--|
| <b>Tool</b>                   | <ul style="list-style-type: none"> <li>• Ratchet, 3/8 inches or smaller                             <ul style="list-style-type: none"> <li>• Hexagon nut, 17 mm WAF</li> <li>• Hexagon socket key, 6 mm WAF</li> <li>• Hexagon socket key, 8 mm WAF</li> </ul> </li> <li>• Ratchet wrench, 13 mm WAF</li> <li>• Allen key, 5 mm WAF</li> <li>• Mounting lever</li> <li>• Soft-face hammer</li> </ul> |
| <b>Adhesives and sealants</b> | Adhesive, e.g. Loctite   |

|                    |   |
|--------------------|---|
| <b>Spare parts</b> | <ul style="list-style-type: none"> <li>• 2 flat gaskets, cutting ring</li> <li>• 2 cutting rings</li> <li>• 2 cutting blades</li> <li>• 1 sealing tape</li> </ul> |
|--------------------|---|

### Preparatory activities

- ▶ Switch off the distributor, → 10.5.2 *Switching off the distributor.*
- ▶ Empty and clean the distributor, → 10.5.7 *Cleaning the DosiMat.*
- ▶ Dismount the service port, → 10.5.3 *Dismounting the service port.*

### Slackening the eccentric adjuster

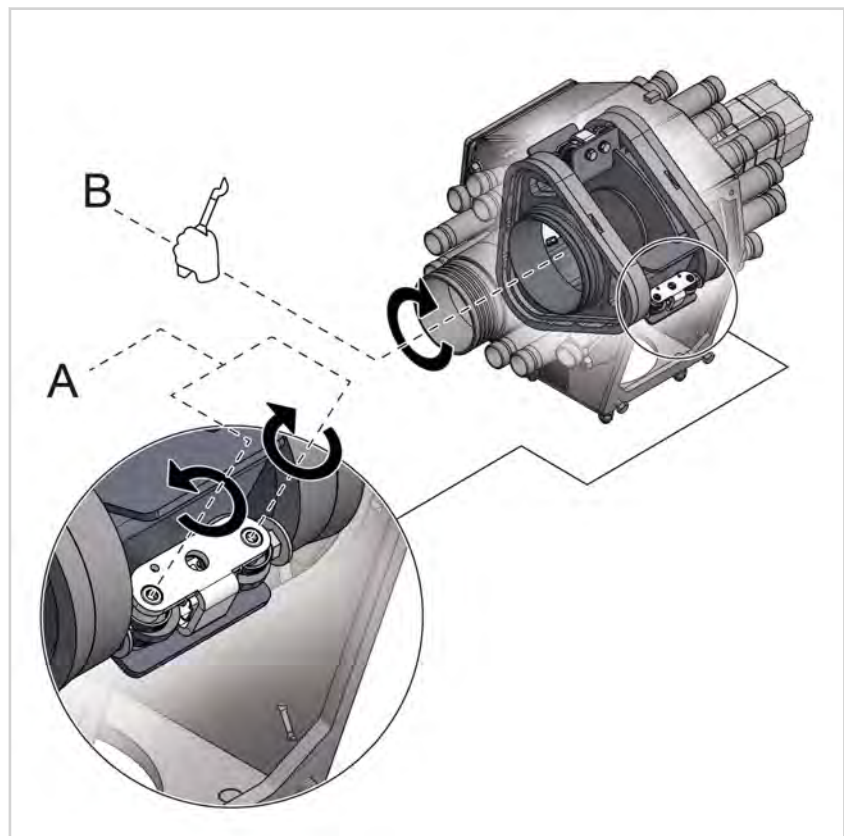

- ▶ Release the preload of the cutting blades by slackening the three eccentric adjusters in the rotor.
  - ▶ Carefully turn the rotor with a mounting lever so that an eccentric adjuster is accessible (B).
  - ▶ Loosen the two hexagon socket head bolts on the eccentric adjuster with a hexagon socket wrench (max. 360°) until you can hear the eccentric washers releasing (A).
  - ▶ Also slacken the other two eccentric adjusters.



### Dismounting the flow plate

- ▶ Undo the centring bolt (2).
- ▶ Remove the centring bolt and the washer from the flow plate (1).

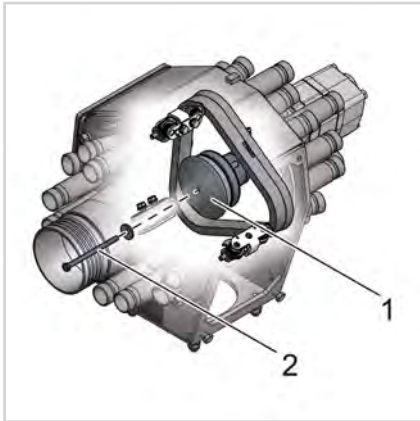

- ▶ Remove the flow plate and the flat gasket (1).

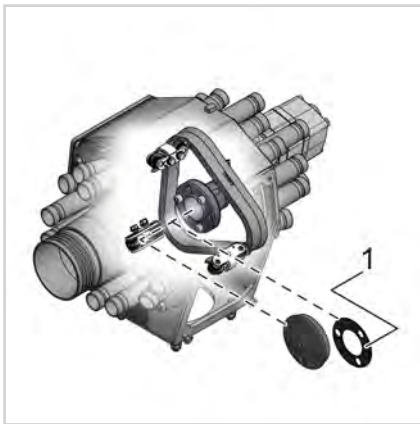

### Dismounting the rotor

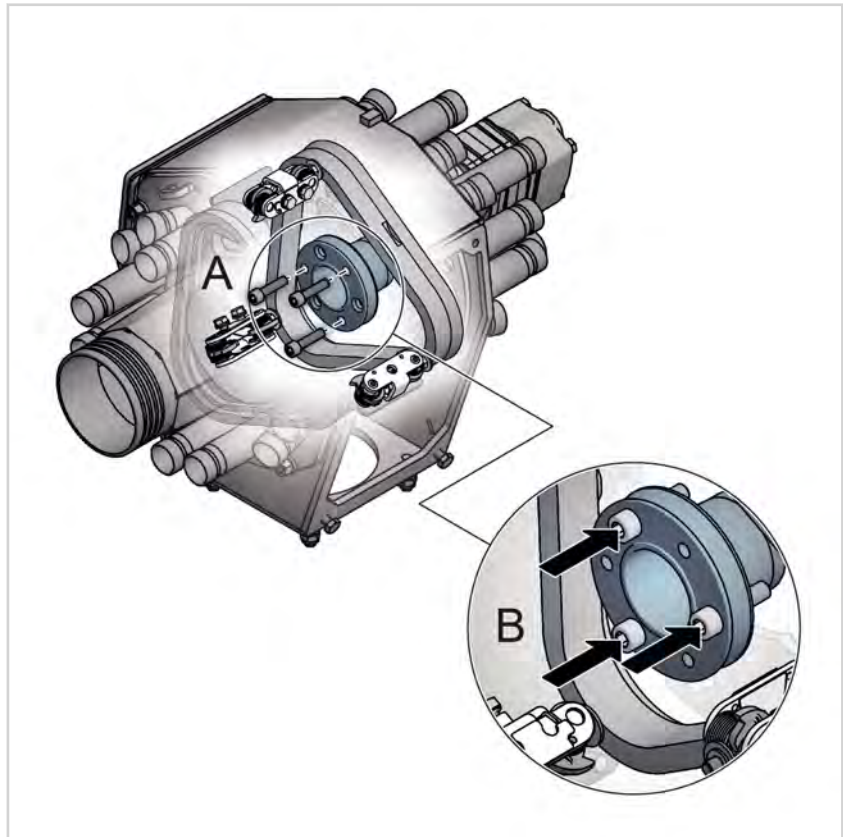

- ▶ Unscrew the three hexagon socket head bolts from the rotor adapter and remove them (A) .

---

#### **i** Notice

After the three bolts have been loosened, the rotor is only held in position by the seal carrier.

- 
- ▶ Screw the three hexagon socket head bolts into the pressure-test threading in the rotor adapter (B) as a disassembly tool.



- ▶ Remove the rotor adapter and the O-ring using the hexagon socket head bolts (A).

**⚠ WARNING!**

**Risk of crushing due to the rotor falling down**

The rotor is no longer held in position after the seal carrier has been pulled out.

The rotor weighs approx. 18 kg.

- ▶ Hold the rotor tightly when unscrewing the bolts.
- ▶ Wear protective clothing.

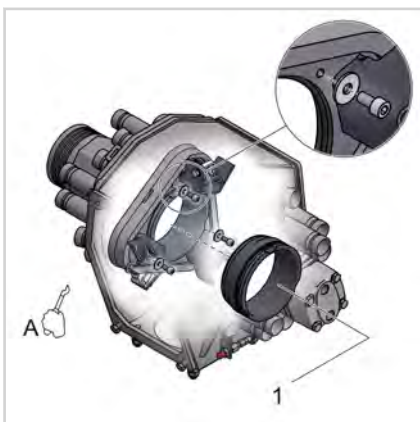

- ▶ Undo the three hexagon socket head bolts from the seal carrier.
- ▶ Remove the screws and washers.
- ▶ Pull out the seal carrier (1) with a mounting lever from its seat (A).

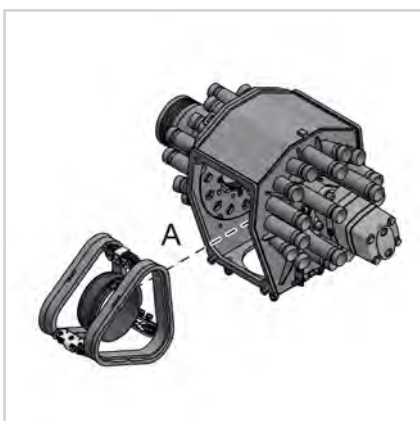

- ▶ Remove the rotor and the seal carrier from the housing (A).

### Dismounting the cutting blades

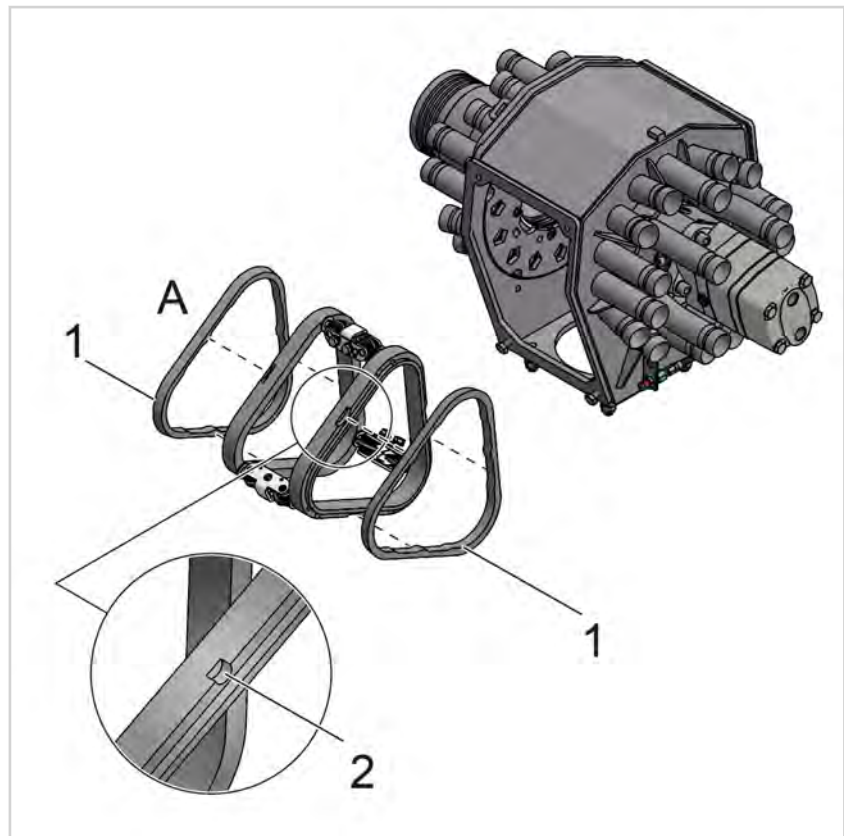

- ▶ Dismount both cutting blades (1) (A).  
To do so, insert a cotter pin drive or mounting lever, for example, in the groove (2) of the blade holder. Pry out the cutting blade.



### Dismounting the cutting ring

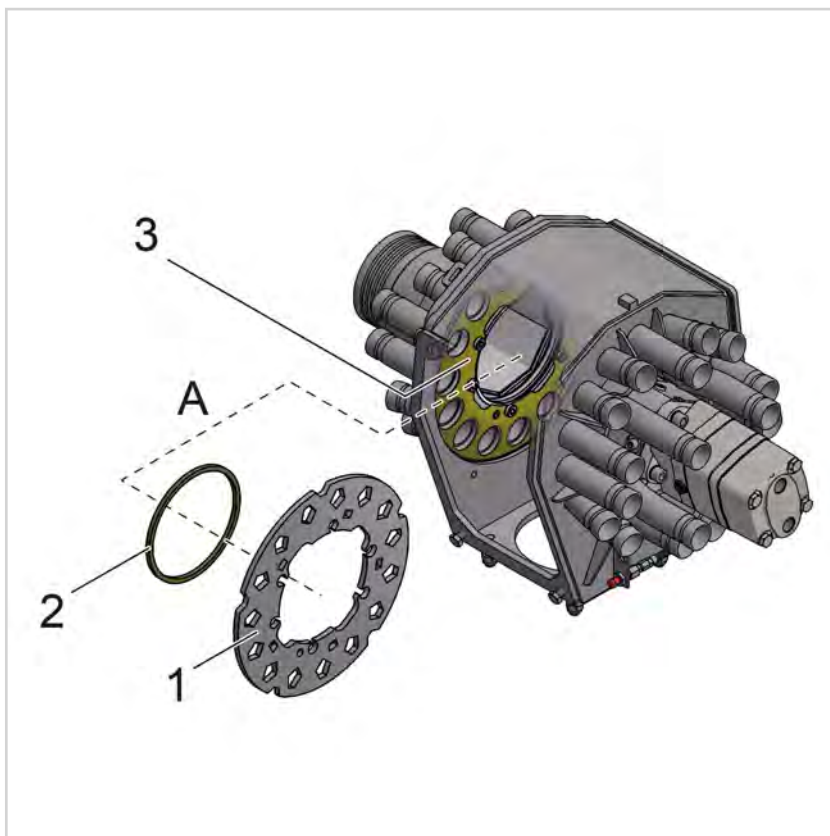

- ▶ Pry both cutting rings (1) out of their seat (A).
- ▶ Remove the flat gaskets (3).
- ▶ Clean the contact surfaces.
- ▶ Check the sealing tape (2) on the inlet side for wear.

### Remounting

- ▶ Replace the sealing tape (2) if it is worn.
- ▶ Place the new flat gaskets (3) and the new cutting rings (1) in the housing (A).
- ▶ Place the new cutting blades on the blade holder and knock them in with a soft-face hammer.
- ▶ Insert the rotor and the seal carrier in the distributor housing (A).

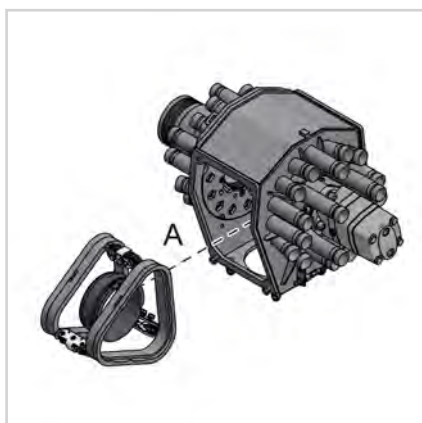

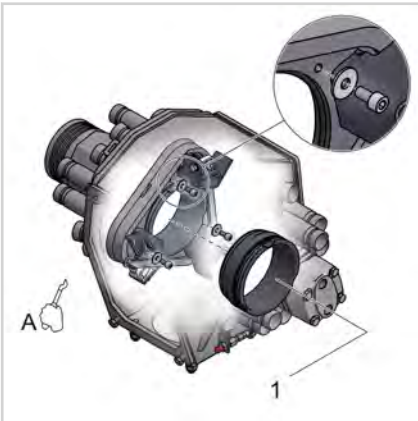

- ▶ Insert the seal carrier (1) in its seat.
- ▶ Reinstall the seal carrier with the three hexagon socket head bolts and the washers.  
Tightening torque: 20 Nm



- ▶ Remove the three hexagon socket head bolts from the rotor adapter.
- ▶ Insert the rotor adapter and the O-ring and reinstall them with the three hexagon socket head bolts (A).  
Tightening torque: 40 Nm

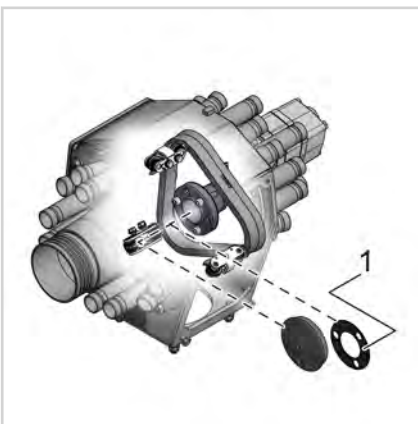

- ▶ Insert the flat gasket (1) and the flow plate.

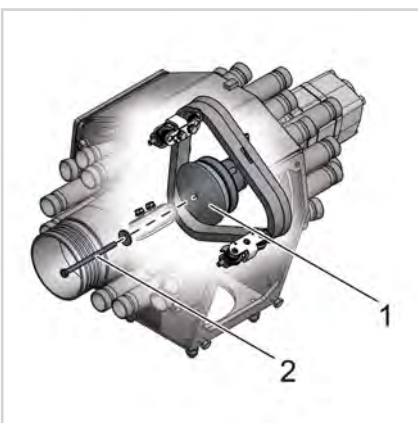

- ▶ Wet the thread of the centring bolt (2) with adhesive.
- ▶ Reinstall the flat gasket and the flow plate with the centring bolt and the washer.  
Tightening torque: 30 Nm

### Tensioning the eccentric adjusters

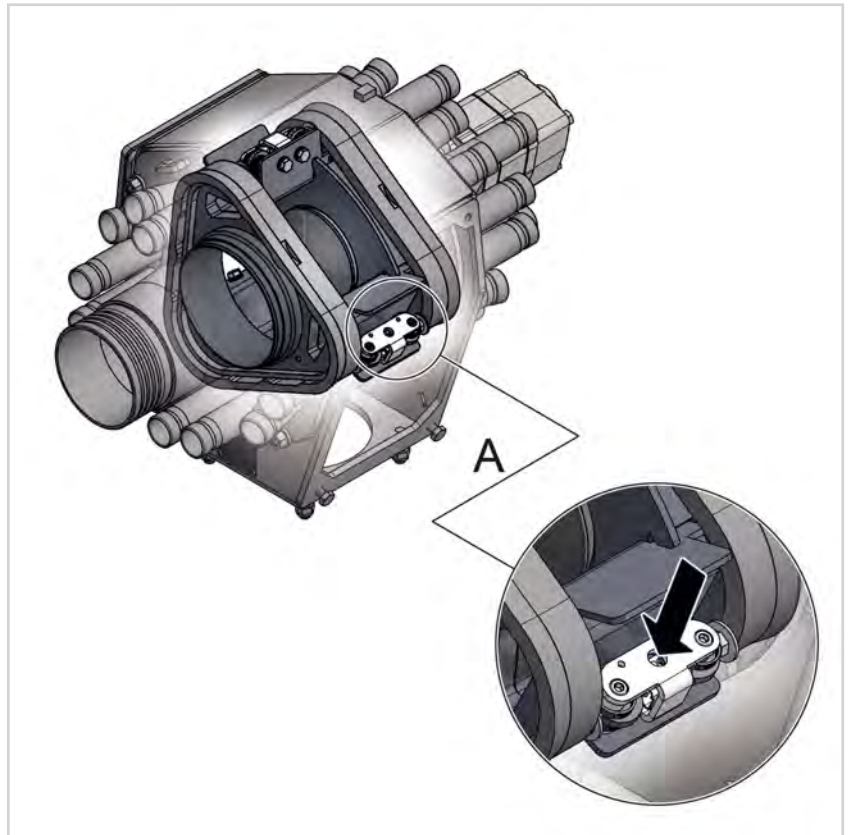

- ▶ Carefully turn the rotor with a mounting lever so that an eccentric adjuster is accessible.
- ▶ Insert the long side of a hexagon socket wrench into the centre borehole of the eccentric adjuster and press it against the spring plates until you can hear the eccentric washers being pre-loaded (A).
- ▶ Also tension the other two eccentric adjusters.

### Concluding activities

- ▶ Install the service port, → 10.5.4 *Installing the service port.*

## 10.5.9 Changing the gaskets

### Dismounting the sealing set

#### **WARNING!**

#### Risk of cutting on sharp-edged parts

If the rotor can be freely accessed, there is a risk of cutting on the sharp edges of the cutting components.

- ▶ Operate the distributor only if the supply hose, the discharge hoses and the foreign matter hose are connected.
- ▶ Only operate the distributor if the maintenance port is mounted and screwed on.
- ▶ Before dismounting the maintenance port, switch the hydraulic valve to "floating position".
- ▶ Switch off the engine of the tractor or spreader vehicle.
- ▶ Before installation, maintenance and repair work, secure moving parts so that they cannot move.
- ▶ Wear protective clothing.

| Part | Sealing set in the rotor   |
|------|--|
| Tool | <ul style="list-style-type: none"> <li>• Hexagon head bolt M 16 x 60</li> <li>• Screwdriver</li> <li>• Circlip pliers</li> </ul> |

#### Preparatory activities

- ▶ Switch off the distributor, → *10.5.2 Switching off the distributor.*
- ▶ Empty and clean the distributor, → *10.5.7 Cleaning the DosiMat.*
- ▶ Dismount the service port, → *10.5.3 Dismounting the service port.*

### Slackening the eccentric adjuster

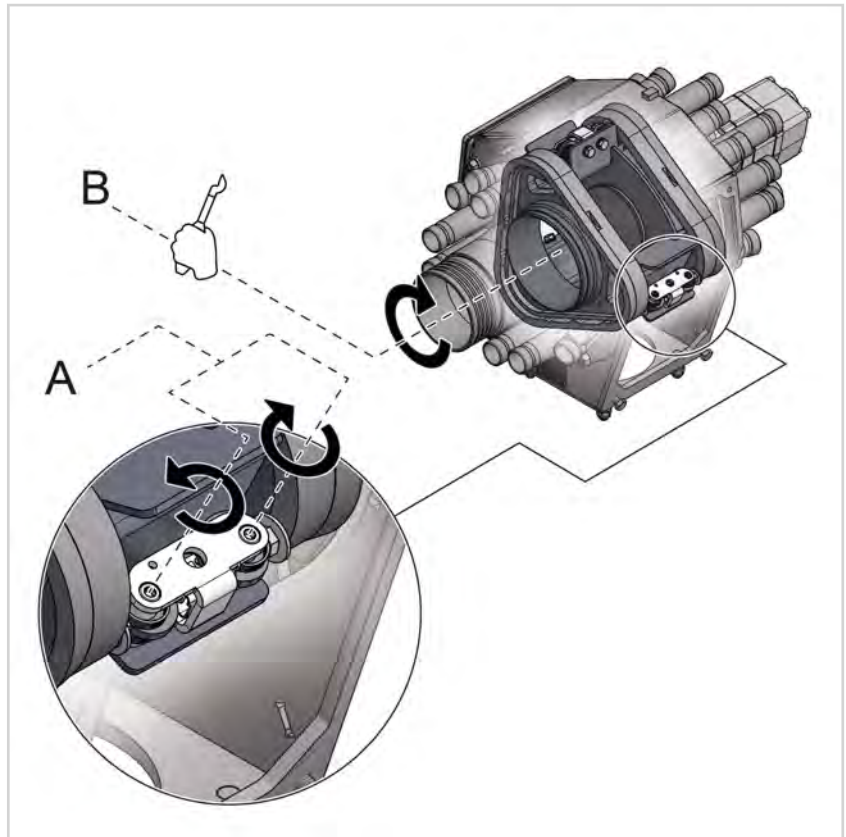

- ▶ Release the preload of the cutting blades by slackening the three eccentric adjusters in the rotor.
  - ▶ Carefully turn the rotor with a mounting lever so that an eccentric adjuster is accessible (B).
  - ▶ Loosen the two hexagon socket head bolts on the eccentric adjuster with a hexagon socket wrench (max. 360°) until you can hear the eccentric washers releasing (A).
  - ▶ Also slacken the other two eccentric adjusters.

### Dismounting the flow plate

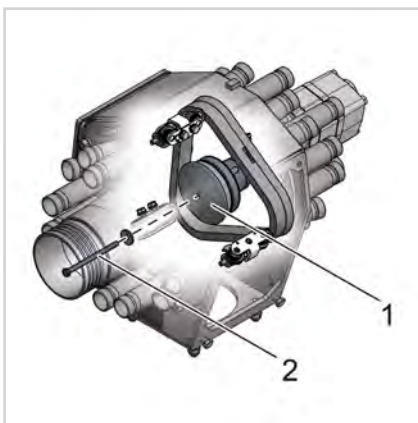

- ▶ Undo the centring bolt (2).
- ▶ Remove the centring bolt and the washer from the flow plate (1).

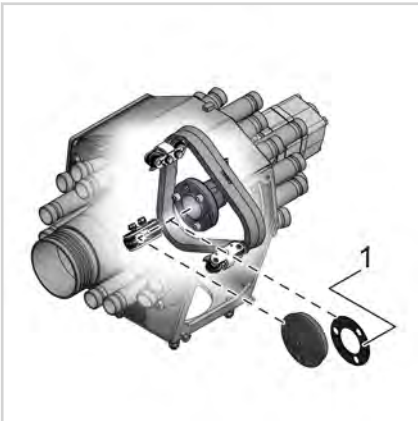

- ▶ Remove the flow plate and the flat gasket (1).

### Dismounting the rotor

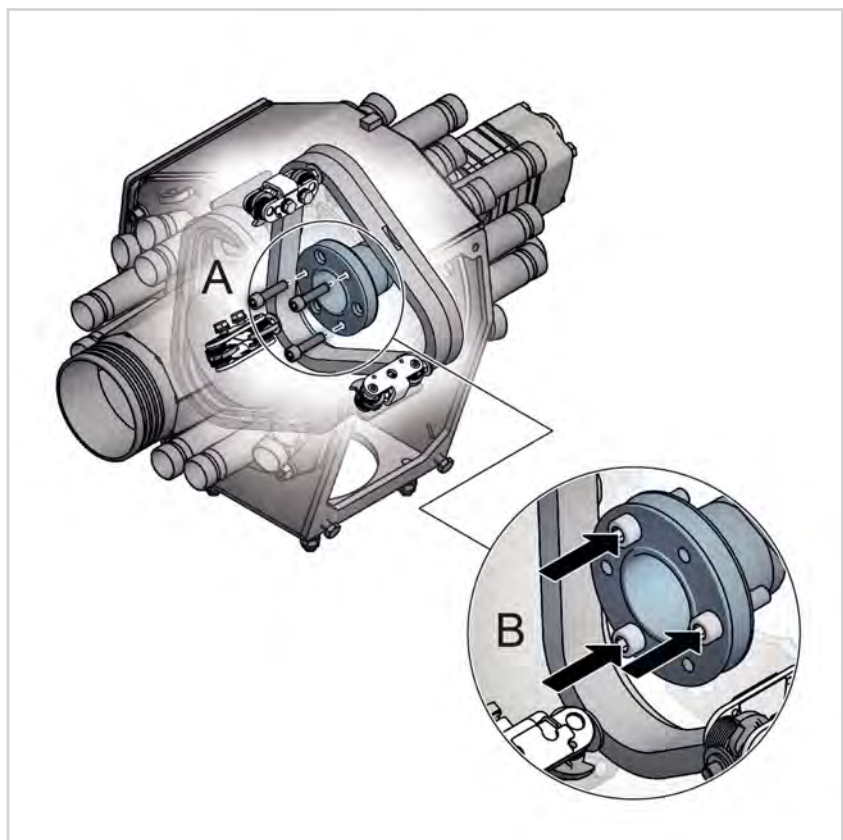

- ▶ Unscrew the three hexagon socket head bolts from the rotor adapter and remove them (A) .

---

#### **i** Notice

After the three bolts have been loosened, the rotor is only held in position by the seal carrier.

---



- ▶ Screw the three hexagon socket head bolts into the pressure-test threading in the rotor adapter (B) as a disassembly tool.
- ▶ Remove the rotor adapter and the O-ring using the hexagon socket head bolts (A).



**⚠ WARNING!**

**Risk of crushing due to the rotor falling down**

The rotor is no longer held in position after the seal carrier has been pulled out.

The rotor weighs approx. 18 kg.

- ▶ Hold the rotor tightly when unscrewing the bolts.
- ▶ Wear protective clothing.

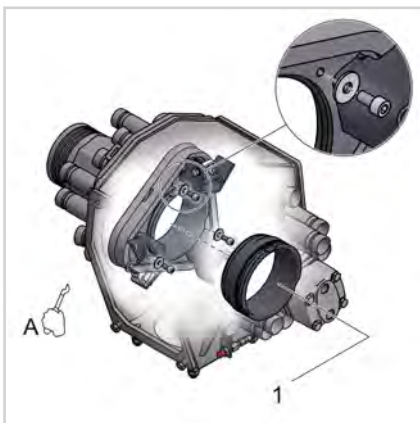

- ▶ Undo the three hexagon socket head bolts from the seal carrier.
- ▶ Remove the screws and washers.
- ▶ Pull out the seal carrier (1) with a mounting lever from its seat (A).

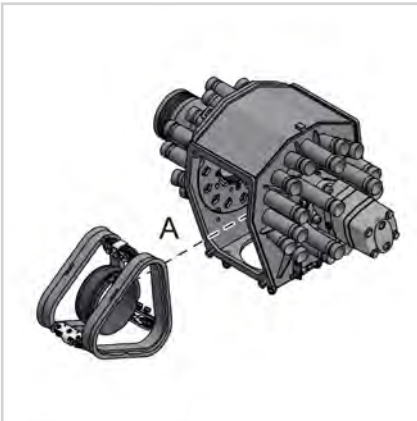

- ▶ Remove the rotor and the seal carrier from the housing (A).

- ▶ Block the motor. To do so, clamp the hydraulics.

### Dismounting the sealing set

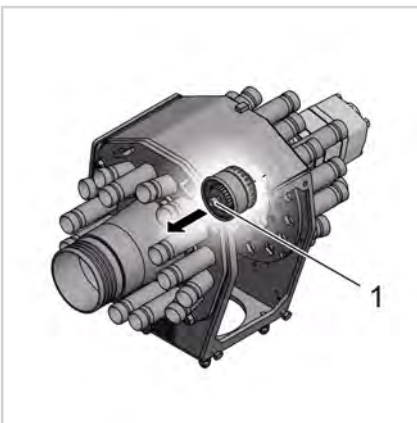

- ▶ Pull out the sealing set with an M 16 x 60 screw (1). The shims are damaged in the process. Note the number of shims.
- ▶ Remove the sealing set.

### Dismounting sealing elements



- ▶ Pry the multi-disc ring (1) with a screwdriver out of the seal carrier (A).



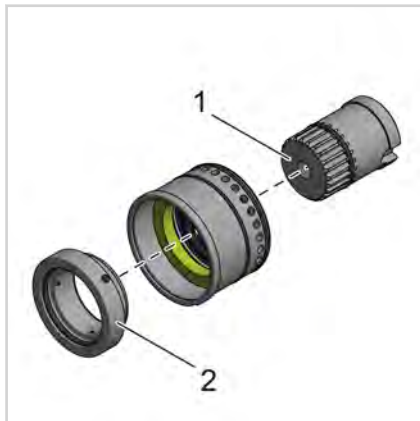

- ▶ Push the drive shaft (1) out of the static seal carrier.
- ▶ Push the rotating seal carrier (2) out of the static seal carrier.

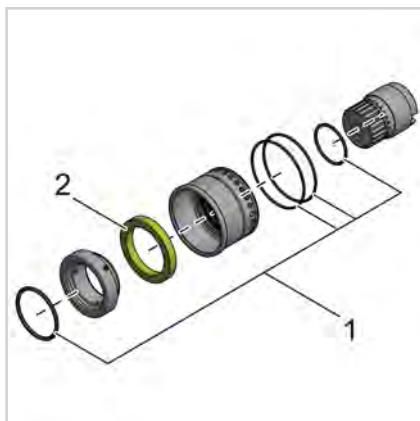

- ▶ Remove all O-rings (1) and the sealing ring (2).



- ▶ Dismount the inner ring (1) from the drive shaft.



- ▶ Dismount the retaining ring (3) with circlip pliers from the static seal carrier.
- ▶ Remove the radial shaft seal rings (1, 2) from the static seal carrier.

## Reinstalling the sealing set

### **WARNING!**

#### Risk of cutting on sharp-edged parts

If the rotor can be freely accessed, there is a risk of cutting on the sharp edges of the cutting components.

- ▶ Operate the distributor only if the supply hose, the discharge hoses and the foreign matter hose are connected.
- ▶ Only operate the distributor if the maintenance port is mounted and screwed on.
- ▶ Before dismounting the maintenance port, switch the hydraulic valve to "floating position".
- ▶ Switch off the engine of the tractor or spreader vehicle.
- ▶ Before installation, maintenance and repair work, secure moving parts so that they cannot move.
- ▶ Wear protective clothing.

|                               |   |
|-------------------------------|---|
| <b>Part</b>                   | Sealing set in the rotor  |
| <b>Tool</b>                   | <ul style="list-style-type: none"> <li>• Hexagon head bolt M 16 x 60</li> <li>• Circlip pliers</li> </ul>                 |
| <b>Adhesives and sealants</b> | <ul style="list-style-type: none"> <li>• Adhesive, e. g. Loctite</li> <li>• Flange sealant AN 305-74 (BKL 103)</li> </ul> |

|                    |   |
|--------------------|---|
| <b>Spare parts</b> | <p>Spare parts set ETS0012</p> <ul style="list-style-type: none"> <li>• Sealing ring (DFD0436)</li> <li>• 2 x O-ring (DOR.039)</li> <li>• O-ring (DOR.072)</li> <li>• O-ring (DOR.084)</li> <li>• Radial shaft seal ring (DWD.015)</li> <li>• Radial shaft seal ring (DWD0051)</li> <li>• Inner ring (NIR.006)</li> <li>• Retaining ring (NSR.025)</li> <li>• Multi-disc ring (NSR0085)</li> <li>• 15 x shim (NUS.067)</li> </ul> |
|--------------------|---|

**Overview of sealing elements**

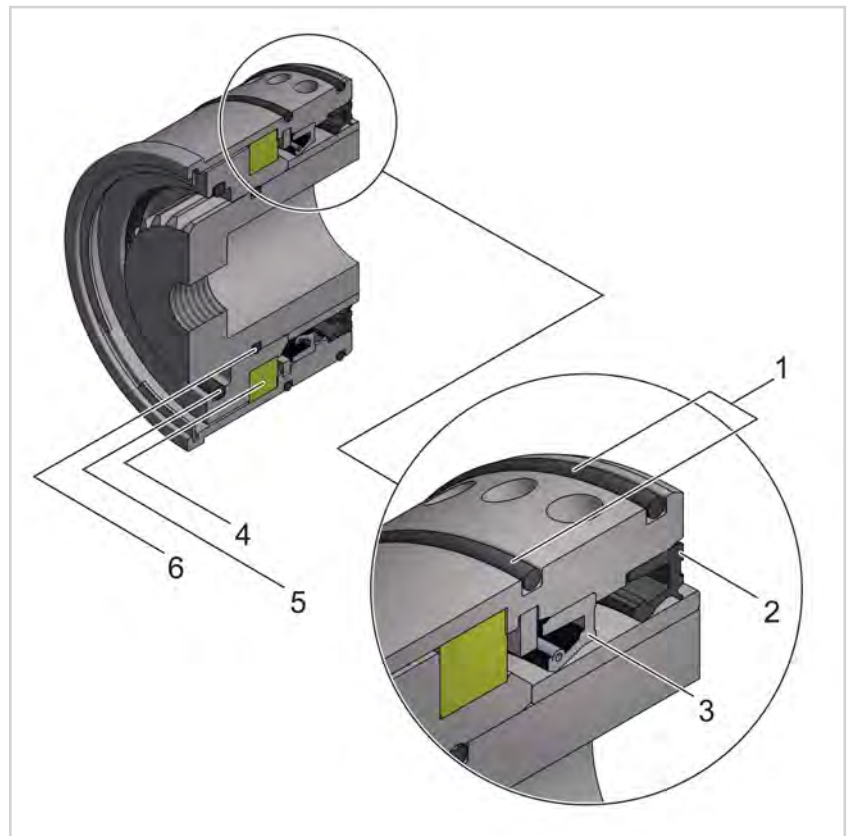

- |   |   |   |              |
|---|---|---|--------------|
| 1 | O-ring                                  | 4 | Sealing ring |
| 2 | Radial shaft seal ring<br>with dust lip | 5 | O-ring       |
| 3 | Radial shaft seal ring                  | 6 | O-ring       |

### Reinstalling the sealing elements

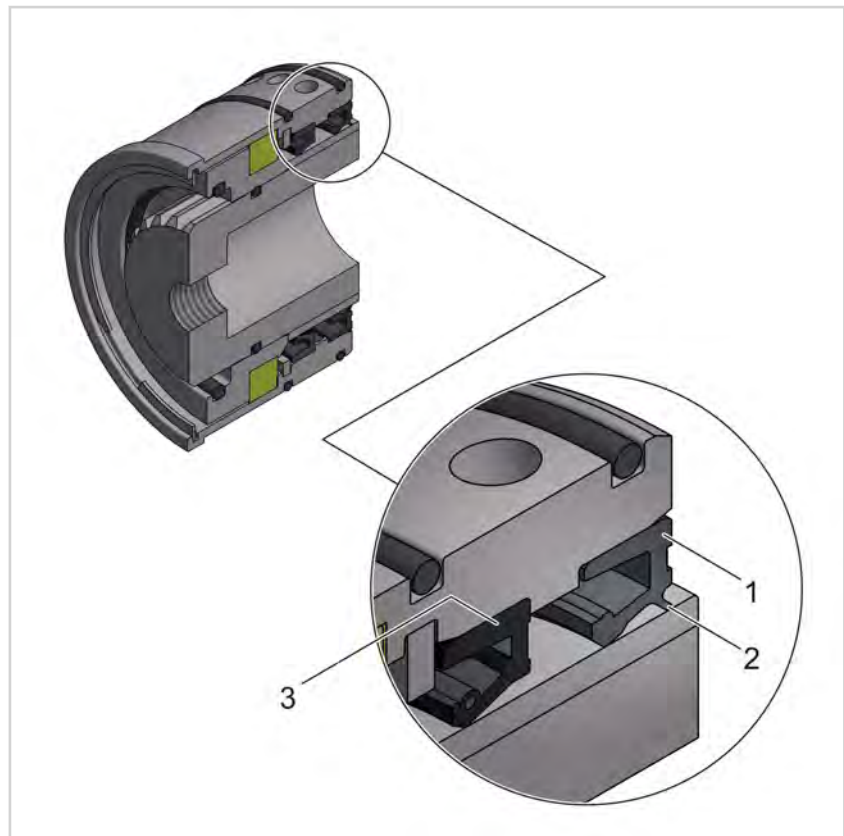

- ▶ Insert the two radial shaft seal rings (1) and (3) in the static seal carrier.



#### Notice

Pay attention to the correct position of the radial shaft seal rings. The dust lip (2) must be on the exterior of the seal carrier.

- 
- ▶ Secure the inside radial shaft seal ring (3) with the retaining ring.



- ▶ Wet the inner ring (1) with adhesive and mount it on the drive shaft.



- ▶ Install the new O-rings (1) and the new sealing ring (2).



- ▶ Insert the rotating seal carrier (1) in the static seal carrier.



- ▶ Install a new multi-disc ring (1).



- ▶ Wet the drive shaft on the tothing with grease or anti-seize paste and insert it in the seal carrier.
- ▶ Wet the shaft seat in the drive shaft with flange sealant.
- ▶ Wet the new shims (1) with lubricant in order for them to stick together.
- ▶ Insert the shims in the drive shaft.

### Reinstalling the sealing set

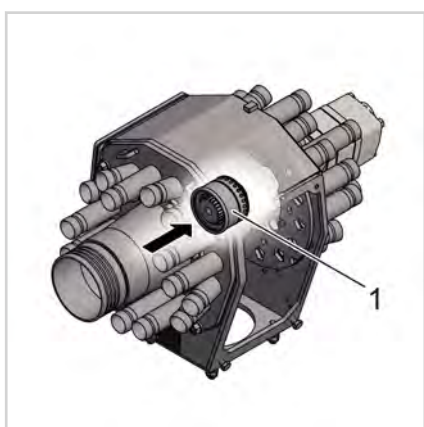

- ▶ Push in the sealing set (1) until the drive shaft and the seal carrier hit the back.

### Mounting the rotor

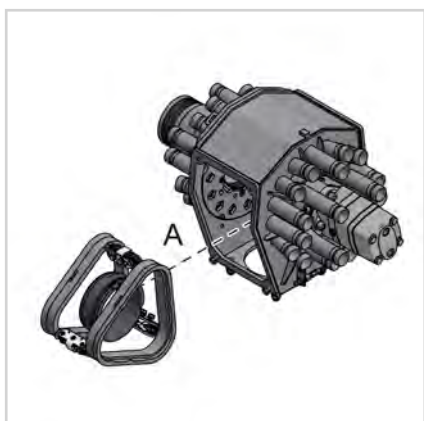

- ▶ Insert the rotor and the seal carrier into the distributor housing (A).

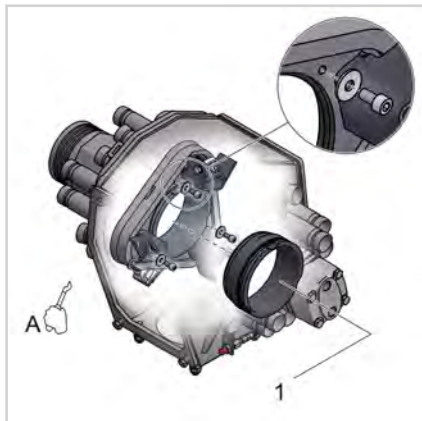

- ▶ Insert the seal carrier (1) in its seat.
- ▶ Reinstall the seal carrier with the three hexagon socket head bolts and the washers.  
Tightening torque: 20 Nm



- ▶ Remove the three hexagon socket head bolts from the rotor adapter.
- ▶ Insert the rotor adapter and the O-ring and reinstall them with the three hexagon socket head bolts (A).  
Tightening torque: 40 Nm

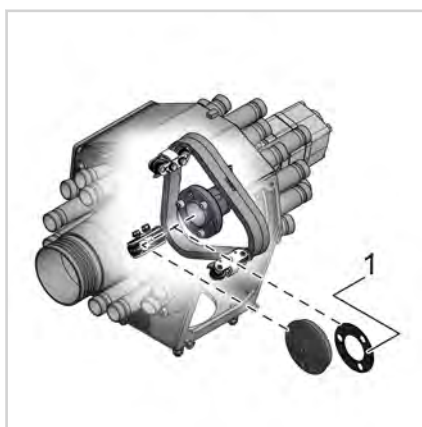

- ▶ Insert the flat gasket (1) and the flow plate.

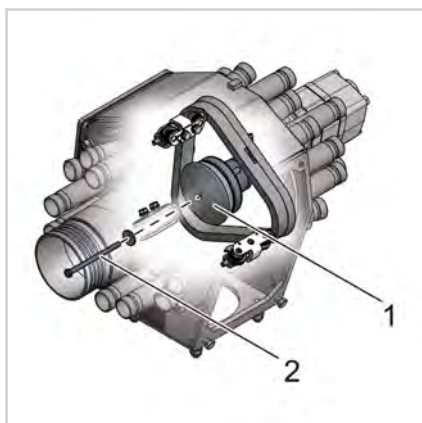

- ▶ Wet the thread of the centring bolt (2) with adhesive.
- ▶ Reinstall the flat gasket and the flow plate with the centring bolt and the washer.  
Tightening torque: 30 Nm



### Tensioning the eccentric adjusters

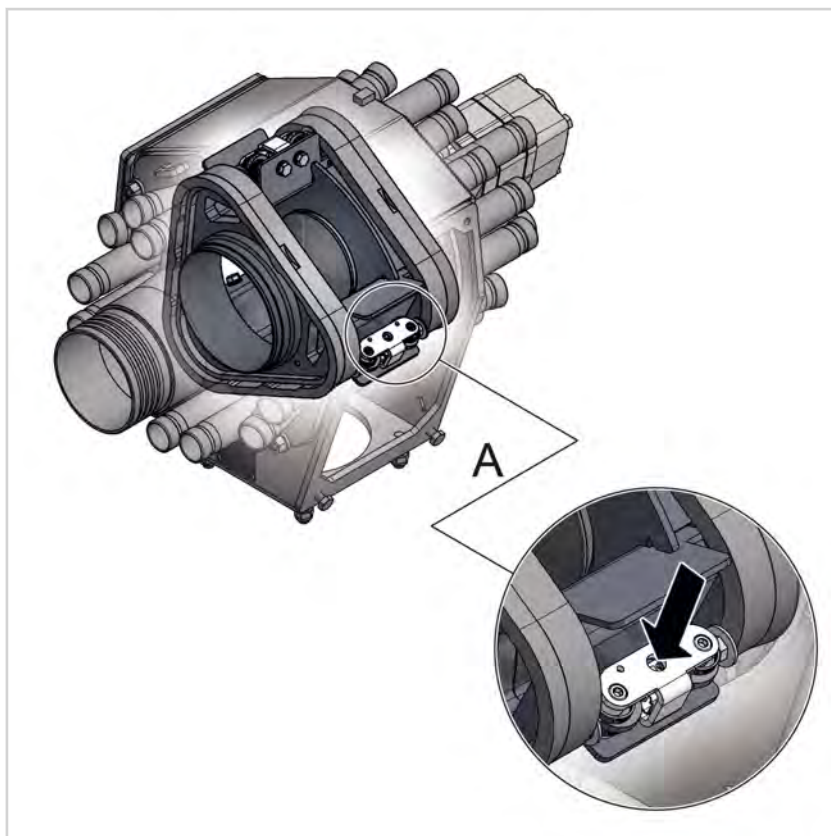

- ▶ Carefully turn the rotor with a mounting lever so that an eccentric adjuster is accessible.
- ▶ Insert the long side of a hexagon socket wrench into the centre borehole of the eccentric adjuster and press it against the spring plates until you can hear the eccentric washers being pre-loaded (A).
- ▶ Also tension the other two eccentric adjusters.

### Concluding activities

- ▶ Install the service port, → 10.5.4 *Installing the service port.*



### 10.5.10 Checking the drive adapter for leaks

|                 |   |
|-----------------|---|
| <b>Part</b>     | Drive adapter   |
| <b>Interval</b> | <ul style="list-style-type: none"> <li>• Every 50 operating hours</li> <li>• After long shutdown periods</li> </ul> |

#### Preparatory activities

- ▶ Switch off the distributor, → 10.5.2 *Switching off the distributor*.

#### Caution!

There is risk of burns due to exposed hot surfaces.

#### Procedure

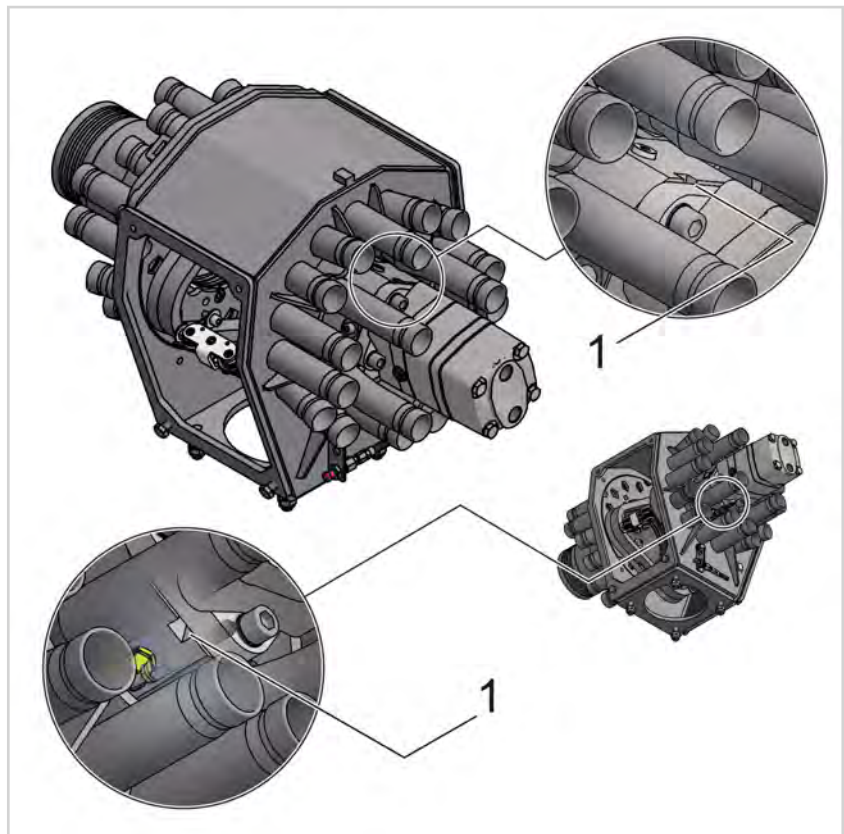

- ▶ Check the drive adapter for leak tightness at the leakage seal indicator pipes (1).
- ▶ If medium is coming out, replace the faulty gaskets, → 10.5.9 *Changing the gaskets*.
- ▶ If oil is coming out, replace the hydraulic motor (Vogelsang service, qualified technical personnel).

### 10.5.11 Lubricating drive adapter

|                    |   |
|--------------------|---|
| <b>Information</b> | We recommend connecting to the central lubrication system.  |
| <b>Part</b>        | Drive adapter   |
| <b>Interval</b>    | <ul style="list-style-type: none"><li>• Every 50 operating hours</li><li>• Before long periods of shut-down</li></ul> |
| <b>Tool</b>        | Lube gun  |
| <b>Lubricant</b>   | Renolit GP2 (part no. BSS.088)<br>NLGI Class 2<br>Water-resistant   |
| <b>Quantity</b>    | 4 strokes   |

**Caution!**  
There is risk of burns due to exposed hot surfaces.



## Procedure

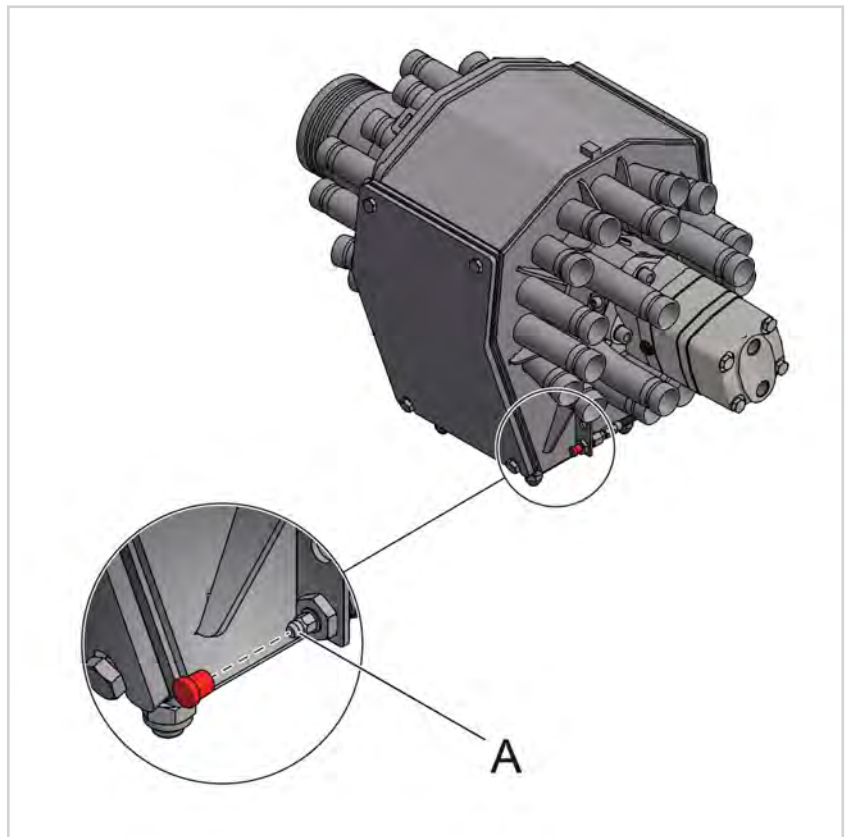

### Notice

To ensure effective distribution of the lubricant, lubricate only when the machine is running.

- 
- ▶ Pull off the grease nipple cap.
  - ▶ Lubricate the drive adapter via the grease nipple (A).
  - ▶ Put on the grease nipple cap.

### 10.5.12 Checking hydraulic hoses and fittings

**⚠ WARNING!**

**Risk of injury due to the failure of hydraulic parts if the maximum permissible hydraulic oil pressure is exceeded**

If the maximum permissible hydraulic oil pressure is exceeded, there is a risk of high pressure injection due to failure of hydraulic components.

- ▶ Observe the maximum permissible hydraulic oil pressure for the DosiMat: max. 200 bar.
- ▶ Observe the maximum permissible hydraulic oil pressure for the hydraulic motor, → Specifications for the hydraulic motor.
- ▶ Wear protective clothing.

**⚠ WARNING!**

**Beware of skin and eye irritation and the risk of infection from contact with hydraulic oil**

Leaks may occur when coupling and uncoupling hydraulic lines or due to faulty seals. Leaking hydraulic oil can cause skin and eye irritation as well as infections.

- ▶ Have hydraulic lines connected by qualified personnel.
- ▶ Wear the appropriate protective clothing.
- ▶ In the event of injuries with hydraulic oil, see a doctor immediately!

|                      |  |
|----------------------|--|
| <b>Attention!</b>    | Hydraulic hoses and fittings are pressurised. Hoses and fittings that are not in safe working condition pose a risk. |
| <b>Qualification</b> | Qualified technical personnel  |
| <b>Part</b>          | Hydraulic hoses and fittings   |
| <b>Interval</b>      | <ul style="list-style-type: none"> <li>• Every 12 months</li> </ul>  |

**Procedure**

- ▶ Check that the hydraulic hoses and fittings are in safe working condition.

Test criteria:

- Damage to the outer layer causing the inner lining to be exposed (e.g. chafe marks, cuts, cracks)
  - Deformation (e.g. crushing, kinks)
  - Blistering
  - Leaks
  - Overageing of the hoses (over 6 years)
  - Hoses working their way out of the fittings
  - Damage or deformation of the fittings
  - Corrosion of the fittings
- ▶ If any hydraulic hoses or fittings are not in safe working condition, replace them.

# 11 Malfunctions and errors

## 11.1 Safety notes

The actions described in this table of malfunctions may be carried out only by persons

- who have been trained for the activities concerned and who possess the necessary knowledge.
- who have been informed about the possible dangers when using the machine.

If specific additional qualifications are required to remedy malfunctions, those will be specified in the section concerned.

### **WARNING!**

#### **Beware the risk of injury from falling from high locations**

Some installation and maintenance work has to be done in higher locations. There is a risk of falling down.

- ▶ Use suitable equipment to climb up, e.g. a scaffold or ladder.
  - ▶ Make sure the scaffold or ladder is stable.
- 

### **WARNING!**

#### **Risk of cutting on sharp-edged parts**

If the rotor can be freely accessed, there is a risk of cutting on the sharp edges of the cutting components.

- ▶ Operate the distributor only if the supply hose, the discharge hoses and the foreign matter hose are connected.
  - ▶ Only operate the distributor if the maintenance port is mounted and screwed on.
  - ▶ Before dismounting the maintenance port, switch the hydraulic valve to "floating position".
  - ▶ Switch off the engine of the tractor or spreader vehicle.
  - ▶ Before installation, maintenance and repair work, secure moving parts so that they cannot move.
  - ▶ Wear protective clothing.
-

**⚠ WARNING!****Risk of cutting on sharp-edged parts during functional test**

If the rotor can be freely accessed, there is a risk of cutting on the sharp edges of the cutting components.

- ▶ A functional test (e.g. to check the safety device or the rotational action of the rotor) may only be carried out by qualified technical personnel.
  - ▶ Before switching on the machine for functional tests, make sure that there are no persons in the danger area.
  - ▶ Wear protective clothing.
- 

**⚠ WARNING!****Danger from bursting distributor housing**

If the maximum permissible internal pressure is exceeded, the DosiMat housing may burst. This may result in injuries.

- ▶ Be sure to observe the maximum permissible internal pressure of the DosiMat: 2 bar.
- 

**⚠ WARNING!****Risk of injury due to the failure of hydraulic parts if the maximum permissible hydraulic oil pressure is exceeded**

If the maximum permissible hydraulic oil pressure is exceeded, there is a risk of high pressure injection due to failure of hydraulic components.

- ▶ Observe the maximum permissible hydraulic oil pressure for the DosiMat: max. 200 bar.
  - ▶ Observe the maximum permissible hydraulic oil pressure for the hydraulic motor, → Specifications for the hydraulic motor.
  - ▶ Wear protective clothing.
-

**⚠ WARNING!****Risk of injury due to the liquid manure supply hose bursting**

If the maximum permissible pressure in the liquid manure supply hose is exceeded, the hose can burst and the medium can splash out. This may result in injuries.

- ▶ Note the maximum permissible pressure in the liquid manure supply hose: 2 bar.
  - ▶ Wear protective clothing.
- 

**⚠ WARNING!****Skin and eye irritations as well as risk of infection due to contact with working materials or the medium**

All work on the machine can lead to contact with working materials or media. Contact may cause skin or eye irritation.

- ▶ Inform staff about hazardous substances.
  - ▶ Wear protective clothing.
  - ▶ Before working on the machine, depressurize it to prevent lubricants and media from squirting out.
- 

**⚠ WARNING!****Beware of skin and eye irritation and the risk of infection from contact with hydraulic oil**

Leaks may occur when coupling and uncoupling hydraulic lines or due to faulty seals. Leaking hydraulic oil can cause skin and eye irritation as well as infections.

- ▶ Have hydraulic lines connected by qualified personnel.
  - ▶ Wear the appropriate protective clothing.
  - ▶ In the event of injuries with hydraulic oil, see a doctor immediately!
-



**⚠ CAUTION!**

**Beware of the risk of burns due to exposed hot surfaces**

During operation the hydraulic oil can reach a temperature of more than 60 °C.  
The hydraulic motor reaches high temperatures in normal operation.  
The DosiMat housing can become very hot during dry running of the cutting blades.

- ▶ Avoid contact with hot surfaces.
- ▶ Avoid dry running of the cutting blades.
- ▶ Operate the DosiMat only when it is filled with the medium to be distributed.
- ▶ Allow the DosiMat to cool down to ambient temperature before starting maintenance and repair work.
- ▶ Wear protective clothing.

**⚠ CAUTION!**

**Scalding or burning by hot medium**

Contact with hot media or working materials over 60 °C can cause scalding or burns.

- ▶ Avoid contact with hot media and working materials.
- ▶ Before maintenance and repair work, flush out the DosiMat and release the pressure.
- ▶ Wear protective clothing.

## 11.2 Table of malfunctions

### 11.2.1 DosiMat is vibrating

| Possible cause      | Possible remedy  |
|---------------------|--|
| Rotor speed too low | <ul style="list-style-type: none"> <li>• Check the volume flow of the hydraulic oil on the spreader vehicle.</li> <li>• Check the hydraulic system.</li> </ul> |
| Rotor is blocked    | <ul style="list-style-type: none"> <li>• Clean the distributor.</li> </ul>   |
| Air ducts blocked   | <ul style="list-style-type: none"> <li>• Clean the air ducts with water.</li> </ul>  |

### 11.2.2 Cutting effect insufficient

| Possible cause               | Possible remedy  |
|------------------------------|--|
| Flow rate too high           | <ul style="list-style-type: none"> <li>Reduce the pump speed.</li> </ul>   |
| Cutting components worn      | <ul style="list-style-type: none"> <li>Replace the cutting components.</li> </ul>  |
| Rotor speed too low          | <ul style="list-style-type: none"> <li>Check the volume flow of the hydraulic oil on the spreader vehicle.</li> <li>Check the hydraulic system.</li> </ul> |
| Eccentric adjuster defective | <ul style="list-style-type: none"> <li>Replace the eccentric adjuster.</li> </ul>  |

### 11.2.3 Poor distribution

| Possible cause                          | Possible remedy  |
|---|--|
| Rotor speed too low                     | <ul style="list-style-type: none"> <li>Check the volume flow of the hydraulic oil on the spreader vehicle.</li> <li>Check the hydraulic system.</li> </ul> |
| Rotor speed too high                    | <ul style="list-style-type: none"> <li>Check the volume flow of the hydraulic oil on the spreader vehicle.</li> </ul>                                      |
| Hose layout incorrect                   | <ul style="list-style-type: none"> <li>Optimise the hose layout. Hoses of roughly similar length should be fed at every rotor position</li> </ul>          |
| Sagging in the discharge hoses          | <ul style="list-style-type: none"> <li>Eliminate the sagging.</li> </ul>   |
| Fibrous matter under the cutting blades | <ul style="list-style-type: none"> <li>Remove the fibrous matter.</li> </ul>   |
| Air ducts blocked                       | <ul style="list-style-type: none"> <li>Clean the air ducts with water.</li> </ul>  |

### 11.2.4 Only a few discharge hoses are being supplied with medium

| Possible cause | Possible remedy   |
|----------------|---|
| Rotor blocked  | <ul style="list-style-type: none"> <li>Reverse the rotor several times.</li> <li>Remove foreign matter.</li> <li>Check the hydraulic system.</li> </ul> |

### 11.2.5 Strong pulsation in the discharge hoses

| Possible cause       | Possible remedy  |
|----------------------|--|
| Rotor speed too low  | <ul style="list-style-type: none"> <li>• Check the volume flow of the hydraulic oil on the spreader vehicle.</li> <li>• Check the hydraulic system.</li> </ul> |
| Rotor speed too high | <ul style="list-style-type: none"> <li>• Check the volume flow of the hydraulic oil at the spreader vehicle.</li> <li>• Check the hydraulic system.</li> </ul> |
| Air ducts blocked    | <ul style="list-style-type: none"> <li>• Clean the air ducts with water.</li> </ul>  |

### 11.2.6 Noises in the hydraulic system

| Possible cause              | Possible remedy  |
|-----------------------------|--|
| Air in the hydraulic system | <ul style="list-style-type: none"> <li>• Check the hydraulic system for leaks.</li> <li>• Replace the oil filter and top up oil if necessary.</li> <li>• Vent and clean the hydraulic system.</li> <li>• Connect the hydraulic system to a separate tank with filter (max. 10 µm). The tank capacity must be double the size of the maximum hydraulic oil volume flow. Allow the entire system to run unpressurised for about 30 minutes.</li> </ul> |

## 12 Disassembly

### 12.1 Safety notes

#### **WARNING!**

##### **Beware the risk of injury from falling from high locations**

Some installation and maintenance work has to be done in higher locations. There is a risk of falling down.

- ▶ Use suitable equipment to climb up, e.g. a scaffold or ladder.
  - ▶ Make sure the scaffold or ladder is stable.
- 

#### **WARNING!**

##### **Risk of crushing or concussion due to falling machine**

The centre of gravity of the machine could shift. When lifting, the machine could become unbalanced and fall down to one side.

- ▶ Before lifting the machine, note its centre of gravity. See, for example, the dimension drawing or the Transport chapter.
  - ▶ Staying beneath lifted loads is prohibited. Have everyone leave the danger zone.
  - ▶ Note and comply with the transport instructions.
- 

#### **WARNING!**

##### **Risk of crushing or concussion due to falling DosiMat**

The DosiMat must not be held in position by means of the connected supply hose. That could cause screw connections to break or fail. The DosiMat could fall.

- ▶ Securely screw the fixing sheets of the DosiMat to the supports of the spreader linkage.
  - ▶ Check the screw connections fastening the DosiMat in accordance with the maintenance plan to ensure they are firmly tightened, and tighten them if needed.
  - ▶ Wear protective clothing.
-

**⚠ WARNING!****Risk of cutting on sharp-edged parts**

If the rotor can be freely accessed, there is a risk of cutting on the sharp edges of the cutting components.

- ▶ Operate the distributor only if the supply hose, the discharge hoses and the foreign matter hose are connected.
  - ▶ Only operate the distributor if the maintenance port is mounted and screwed on.
  - ▶ Before dismounting the maintenance port, switch the hydraulic valve to "floating position".
  - ▶ Switch off the engine of the tractor or spreader vehicle.
  - ▶ Before installation, maintenance and repair work, secure moving parts so that they cannot move.
  - ▶ Wear protective clothing.
- 

**⚠ WARNING!****Risk of injury due to the failure of hydraulic parts if the maximum permissible hydraulic oil pressure is exceeded**

If the maximum permissible hydraulic oil pressure is exceeded, there is a risk of high pressure injection due to failure of hydraulic components.

- ▶ Observe the maximum permissible hydraulic oil pressure for the DosiMat: max. 200 bar.
  - ▶ Observe the maximum permissible hydraulic oil pressure for the hydraulic motor, → Specifications for the hydraulic motor.
  - ▶ Wear protective clothing.
- 

**⚠ WARNING!****Beware of skin and eye irritation and the risk of infection from contact with hydraulic oil**

Leaks may occur when coupling and uncoupling hydraulic lines or due to faulty seals. Leaking hydraulic oil can cause skin and eye irritation as well as infections.

- ▶ Have hydraulic lines connected by qualified personnel.
  - ▶ Wear the appropriate protective clothing.
  - ▶ In the event of injuries with hydraulic oil, see a doctor immediately!
-

**⚠ WARNING!****Skin and eye irritations as well as risk of infection due to contact with working materials or the medium**

All work on the machine can lead to contact with working materials or media. Contact may cause skin or eye irritation.

- ▶ Inform staff about hazardous substances.
  - ▶ Wear protective clothing.
  - ▶ Before working on the machine, depressurize it to prevent lubricants and media from squirting out.
-

## 12.2 Dismounting the DosiMat

|                       |                                    |
|-----------------------|------------------------------------|
| <b>Qualifications</b> | Qualified technical personnel      |
| <b>Material</b>       | Collecting container for waste oil |

### Preparatory activities

- ▶ Switch off the distributor, → 10.5.2 *Switching off the distributor.*
- ▶ Clean the distributor, → 10.5.7 *Cleaning the DosiMat.*

### Procedure

- ▶ Dismount the hydraulic hose line from the grease nipple and the central lubrication system, and screw on the grease nipple cap.
- ▶ Dismount the overflow oil connector of the hydraulic motor. Collect the oil that comes out.
- ▶ Dismount the hydraulic hose line of the hydraulic motor. Collect the oil that comes out.
- ▶ Dismount the discharge hoses and the ventilation hoses.
- ▶ Dismount the foreign matter hose.

#### Warning!

**The cleaning port is clear when the foreign matter hose has been dismantled. There is a risk of injury from the sharp-edged cutting blades inside the distributor.**

- ▶ Dismount the supply hose.
- ▶ Position a crane with hoisting gear over the distributor.
- ▶ Place the slings (e. g. ropes or lifting straps) close to the distributor housing on both sides around the outlet connectors.
- ▶ Set the distributor down, for example, on a Euro pallet or place it in a skeleton box and secure it for transport.



#### Notice

Dispose of the waste oil in an environmentally friendly manner.

---

## 13 Disposal

### 13.1 Safety notes

#### **CAUTION!**

**Improper handling of oil, grease and other pollutants can pose health risks.**

The consequences of this might be skin reactions, allergies and environmental damage.

- ▶ When handling pollutants and other chemical substances, observe the safety regulations applicable to the products concerned.
- ▶ Avoid skin contact with pollutants. Wear suitable protective clothing.
- ▶ Dispose of pollutants in an environmentally friendly manner.

---

#### **Note:**

- Sort residual medium, pollutants and replacement parts according to their type and dispose of them in an environmentally-friendly manner.
- When handling a medium, always observe the valid safety instructions for the substance concerned.
- Avoid contact with pollutants. Wear suitable protective clothing.





## 13.2 Measures for disposal

- ▶ Dismantle the machine.
- ▶ Sort the working materials according to type and method of disposal.
- ▶ For scrapping, sort the individual parts according to materials and type of disposal.

| Materials               | Disposal                          |
|-------------------------|-----------------------------------|
| Metals                  | Scrap                             |
| Electric components     | Electrical scrap                  |
| Plastic parts           | Non-recyclable waste <sup>3</sup> |
| Gear oil, hydraulic oil | Collection point for waste oil    |

Tab. 4: Materials and disposal



### Notice

Dispose of all working materials and other materials in an environmentally friendly manner.

3) Observe regional disposal regulations and recycling options.

## 14 Appendix

### 14.1 Declaration of installation

#### **Declaration of installation for a partly completed machine (2006/42/EC annex II B)**

We hereby declare that the machine referred to in the following is a partly completed machine. The start-up is forbidden until the machine in which this partly completed machine is installed complies with the provisions of the Machinery Directive **EC directive 2006/42/EC**.

#### **Manufacturer**

Vogelsang GmbH & Co. KG  
Holthöge 10-14  
49632 Essen (Oldenburg), Germany

#### **Product**

Volumetric metering unit for liquid manure spreader vehicles

#### **Machine type**

ExaCut  
ECQ24-40  
ECQ24-50  
ECQ30-40  
ECQ30-4050  
ECQ36-40  
ECQ42-40  
ECQ48-40

The following basic health and safety requirements according to Annex I of the Machinery Directive EC directive 2006/42/EC are applied and observed:

1.1.3; 1.1.5; 1.3.2; 1.5.3; 1.5.4; 1.6.1; 1.6.5; 1.7.1.1; 1.7.3;  
1.7.4.1; 1.7.4.3

### **Applied harmonised standards**

DIN EN ISO 12100:2010  
DIN EN ISO 4413:2010

The special technical documents according to annex VII B have been prepared and can be obtained if necessary.

Vogelsang GmbH & Co. KG; Holthöge 10-14; 49632 Essen (Oldenburg), GERMANY is authorised to compile the technical documentation

The manufacturer is obligated to electronically forward the relevant technical documentation for the partly completed machine to national authorities upon justified request.

49632 Essen, 2019-08-27



*Harald Vogelsang (Managing Director)*

## 14.2 Dimension Drawing

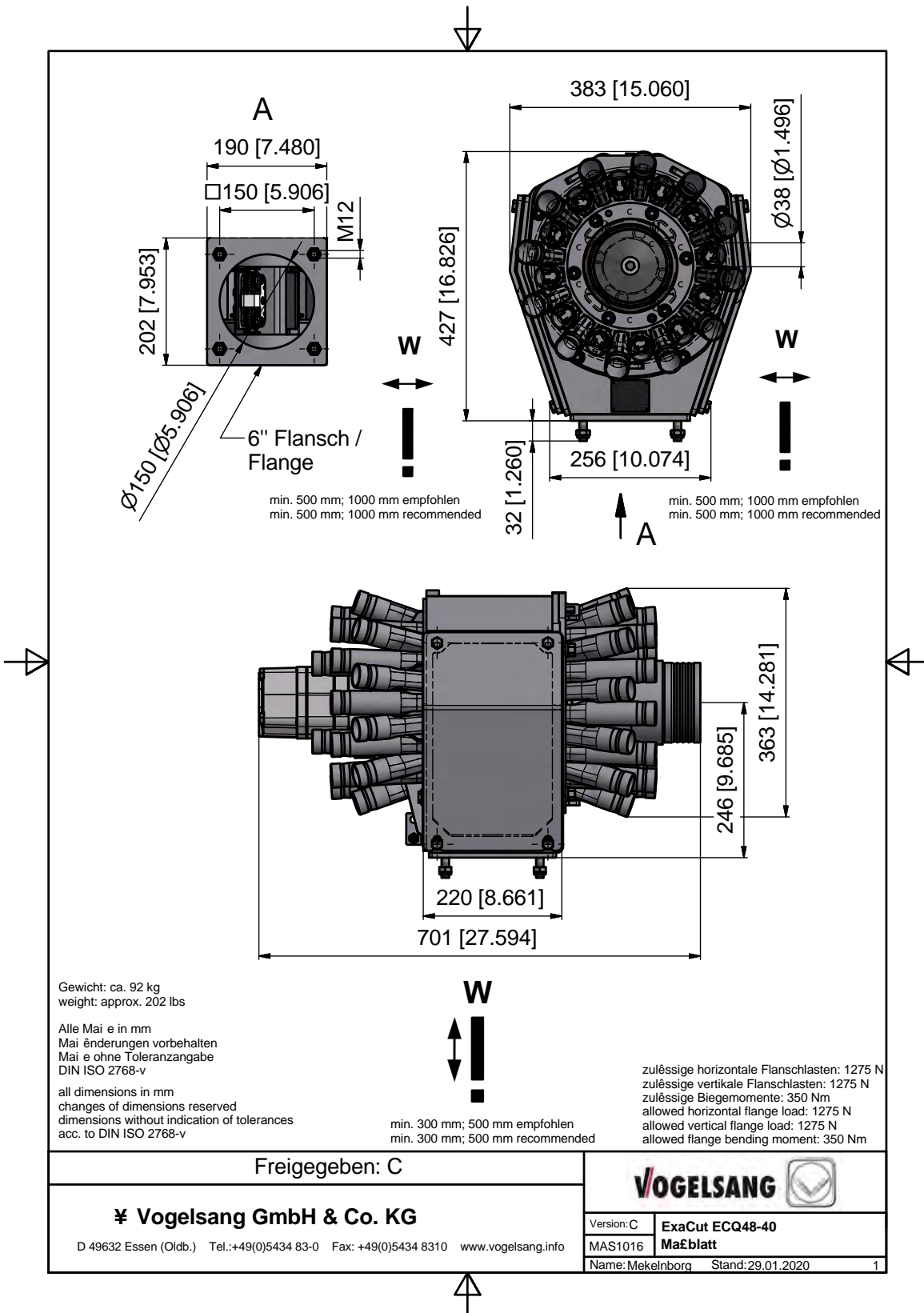

## 14.3 Data Sheet

### 14.3.1 Pressure sensor



Pressure measurement



Type:  
**Precont® PU4SC**

Universal pressure transmitter / pressure switch  
for general industrial applications

Technical information TI09.18

In brief



Application

- Machinery and plant engineering
- Air-conditioning and refrigeration plant engineering
- Hydraulic and pneumatic systems
- Process industry
- Environmental technology
- Facility and building automation

Main features

- Measuring ranges from 50 mbar up to 20 bar
- Wide variety of process connections
- Robust ceramic front-flush or internal diaphragm
- Precise dry capacitive sensor
- Process temperature range  $-40^{\circ}\text{C}$  to  $+125^{\circ}\text{C}$
- Fully welded robust steel enclosure
- High protection class IP69K/IP67
- Highest accuracy to  $\leq 0.05\%$
- Electronic 4...20mA HART® / RS485 Modbus®-RTU / IO-Link®
- Certification ATEX / IECEx: Ex ia IIC Ga / Ex ia IIIC Da

Description

The device is an electronic pressure transmitter / pressure switch for monitoring, control and continuous measurement of pressures. A high variety of versions of process connections and electronic types allows the use for a wide range of applications, also for demanding measuring requirements. The front-flush process connection enables the cleanability of the wetted diaphragm to be integrated into the process, also by CIP/SIP cleaning processes. Low-maintenance and trouble-free pressure measurement is thus also guaranteed in critical applications with viscose or also frequently changing media. Due to its high accuracy and the digital adjustability by HART®, RS485 Modbus®-RTU or IO-Link® the device can be suited to a wide variety of

applications. The robust design and the high-quality workmanship turns the device into a very high quality product, which even the most adverse environmental conditions cannot affect, whether the lowest temperatures when used outdoors, extreme shock and vibration stress or aggressive media. A captive laser marking of the type label ensures the identifiability throughout the entire lifetime of the device. Obviously is the optional marking of a measurement point designation resp. TAG, a customer label or of a neutral type label, of course also per laser marking. A LABS- resp. silicone-free version, a factory calibration with calibration certificate and a customer specific configuration resp. preset is also optionally available like a material test



certificate EN10204 3.1 or a factory certifications for drink water suitability. Customer specific special versions can be realized short-term on request, e.g. special designs for the process connection or other process materials.



Technical Data

|   |   |
|---|---|
| <b>Measuring range</b>                        |   |
| Nominal pressure PN                           | -0,1...0bar / -0,1...0,1bar / -1...0bar / -1...1bar / 0...0,05bar to 0...20bar  |
| <b>Output type A – Current 4...20mA HART®</b> |   |
| Analogue output 4...20mA                      | 3,9...20,5mA / $\geq 3,8\text{mA}$ / $\leq 22\text{mA}$ / $dl \leq 1\mu\text{A}$  |
| Time behavior                                 | T90 $\leq 8\text{ms}$ / ton $\leq 0,2\text{s}$  |
| Interface                                     | HART®-compliant (7.0) / 1200 Bit/s  |
| <b>Output type V – RS485 Modbus®-RTU</b>      |   |
| Interface                                     | RS485, bidirectional / Modbus®-RTU / 9600 Baud (4800...38400 Baud)  |
| Time behavior                                 | T90 $\leq 2\text{ms}$ ( $t_d = 0\text{s}$ ) / ton $\leq 0,1\text{s}$ ( $t_d = 0\text{s}$ )  |
| <b>Output type L – IO-Link®</b>               |   |
| Interface                                     | IO-Link® V1.1 / Com2 (38400 Baud)   |
| Analogue output                               | 0...20mA: 0...20,5mA / $\leq 0,05\text{mA}$ / $\leq 22\text{mA}$ / $dl \leq 1\mu\text{A}$<br>4...20mA: 3,8...20,5mA / $\geq 3,6\text{mA}$ / $\leq 22\text{mA}$ / $dl \leq 1\mu\text{A}$   |
| Switch output                                 | 2x PP (Push-Pull), switch to +L/-L  |
| Output  | Uout $\leq 0,2\text{V}$ , $\geq U_s - 2\text{V}$ / Iout 0...200mA (current limited $\leq 450\text{mA}$ , short circuit protected)   |
| Time behavior                                 | T90 $\leq 2\text{ms}$ / ton $\leq 0,1\text{s}$  |
| <b>Auxiliary power</b>                        |   |
| Supply voltage $U_s$<br>polarity protected    | Type A – 4...20mA HART®: 9...35VDC / Ex: 9...30VDC<br>Type V – RS485 Modbus®-RTU: 6...35VDC<br>Type L – IO-Link®: 9...35VDC, without IO-Link® / 18...30VDC, with IO-Link®   |
| <b>Measuring accuracy</b>                     |   |
| Characteristic deviation                      | $\leq \pm 0,05\%$ / $\pm 0,1\%$ / $\pm 0,2\%$ FSO   |
| Long term drift                               | $\leq \pm 0,15\%$ FSO/year  |
| Temperature deviation                         | Tk Zero $\leq \pm 0,015\%$ FSO/K, $\leq \pm 0,75\%$ FSO (-20°C...+80°C)<br>Tk Span $\leq \pm 0,015\%$ FSO/K<br>$\leq \pm 0,5\%$ FSO (-20°C...+80°C/ $\geq 0,4\text{bar}$ ) / $\leq \pm 0,8\%$ FSO (-20°C...+80°C/ $< 0,4\text{bar}$ ) |
| <b>Process conditions</b>                     |   |
| Process temperature                           | Standard: -40°C...+100°C<br>Extended: -40°C...+125°C (+140°C – 1h)  |
| Pressure cycles                               | $\geq 100$ Mio. (1,2xPN)  |
| <b>Environmental conditions</b>               |   |
| Environmental temperature                     | -40°C...+100°C  |
| Protection level                              | IP69K/IP67 (EN/IEC 60529)   |
| MTTF  | 463 years   |

Electrical connection

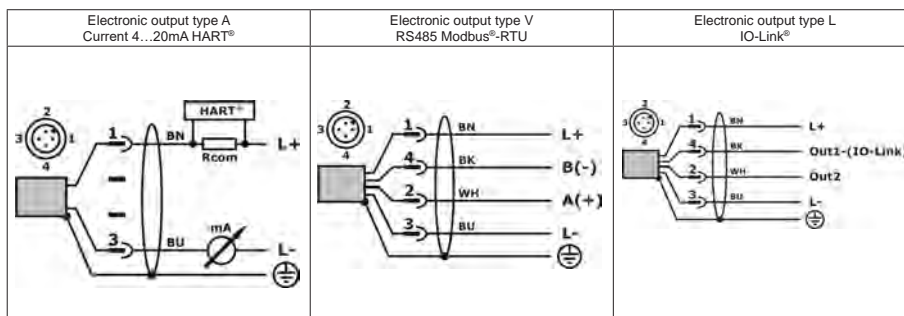

Dimensions (mm)



|   |  |  |
|---|--|--|
| <p>Terminal enclosure</p>   |  | <p>Temperature decoupler<br/>Extended temperature range</p>                                  |
| <p>Process connection type 6<br/>Thread G<math>\frac{1}{4}</math>"A, EN 837</p>       | <p>Process connection type 1<br/>Thread G<math>\frac{1}{2}</math>"A, EN 837</p>      | <p>Process connection type 3<br/>Thread G<math>\frac{1}{2}</math>"A, DIN EN ISO 1179-2 E</p> |
| <p>Process connection type 4<br/>Thread G<math>\frac{1}{4}</math>"I, inner thread</p> |  |  |
| <p>Process connection type 9<br/>Thread G<math>\frac{1}{2}</math>"A, front-flush</p>  | <p>Process connection type 8<br/>Thread G<math>\frac{3}{4}</math>"A, front-flush</p> | <p>Process connection type 5<br/>Thread G1"A, front-flush</p>                                |

You will find further dimension drawings in the technical information.



Order code



|      |  |  |
|------|--|--|
| PU4S | Type   | Standard   |
| C    | Measuring system – material diaphragm (process wetted) / sensor type | Ceramic Al <sub>2</sub> O <sub>3</sub> 96%/99,7%/99,9% / capacitive                        |
| S    | Approval   | Standard   |
| X    |  | ATEX II 1 G / IECEx Ex ia IIC Ga resp. ATEX II 1 D / IECEx Ex ia IIIC Da (Output type – A) |
| 6    | Process connection   | Thread ISO 228-1 – G $\frac{1}{2}$ "A, EN 837 manometer                                    |
| 1    |  | Thread ISO 228-1 – G $\frac{1}{2}$ "A, EN 837 manometer                                    |
| 3    |  | Thread ISO 228-1 – G $\frac{1}{2}$ "A, DIN EN ISO 1179-2 E                                 |
| 4    |  | Thread ISO 228-1 – G $\frac{1}{2}$ "I, inner thread  |
| 9    |  | Thread ISO 228-1 – G $\frac{1}{2}$ "A, front-flush   |
| 8    |  | Thread ISO 228-1 – G $\frac{1}{2}$ "A, front-flush   |
| 5    |  | Thread ISO 228-1 – G $\frac{1}{2}$ "A, front-flush   |
| R    |  | Dairy coupling DIN 11851 – DN25, PN40  |
| N    |  | Dairy coupling DIN 11851 – DN40, PN40  |
| M    |  | Dairy coupling DIN 11851 – DN50, PN25  |
| P    |  | Varivent® – Type N / Ø68mm / tube DN40-162 / 1 $\frac{1}{2}$ "-6", PN40                    |
| L    |  | DRD – DN50 / Ø65mm, PN25   |
| S    |  | Clamp ISO 2852 – DN25-38 / BS 4825 – 1"-1 $\frac{1}{2}$ " / DIN 32676 – DN25-38, PN40      |
| T    |  | Clamp ISO 2852 – DN40-51 / BS 4825 – 2" / DIN 32676 – DN50, PN40                           |
| Y    |  | others   |
| 1    | Material process gaskets (process wetted)                            | FPM – fluorelastomere (e.g. Viton®)  |
| 3    |  | EPDM – ethylene-propylene-dienmonomere, FDA-listed   |
| 4    |  | FFKM – perfluorelastomere (e.g. Kalrez®)   |
| 6    |  | FFKM hd - perfluorelastomere high density - gas applications                               |
| Y    |  | others   |
| V    | Material process connection (process wetted)                         | CrNi-steel   |
| C    | Material terminal enclosure  | CrNi-steel   |
| 26   | Measuring range  | 0..50 mbar 09 0..6 bar   |
| 01   |  | 0..100 mbar 10 0..10 bar   |
| 02   |  | 0..200 mbar 11 0..16 bar   |
| 03   |  | 0..400 mbar 12 0..20 bar   |
| 04   |  | 0..600 mbar 15 -100..0 mbar  |
| 05   |  | 0..1 bar 16 -1..0 bar  |
| 06   |  | 0..1.6 bar 17 -1..+1 bar   |
| 07   |  | 0..2.5 bar 18 -100..+100 mbar  |
| 08   |  | 0..4 bar YY Special measuring range  |
| A    | Electronic – output  | Current 4...20mA, HART®-compliant, 2-wire  |
| V    |  | RS485 Modbus®-RTU, 4-wire  |
| L    |  | IO-Link®, 1x current 0/4...20mA / 2x switch, 4-wire  |
| S    | Electronic – function  | Standard   |
| 0    | Process temperature  | Standard –40°C...+100°C  |
| 1    |  | Extended –40°C...+125°C, temperature decoupler   |
| R    | Pressure type  | Gauge pressure   |
| A    |  | Absolute pressure (FS $\geq$ 100mbar)  |
| 1    | Measuring system – accuracy  | 0.2%   |
| 3    |  | 0.1% (FS $\geq$ 100mbar), linearization protocol   |
| 6    |  | Xcellence – 0.05% (FS $\geq$ 200mbar), linearization protocol                              |
| S    | Electrical connection  | Plug M12x1   |
| -SF  | Additional options   | LABS-free, silicone-free / paint compatible version  |
| -ML  |  | Measurement point designation / TAG – Laser marking  |
| -KL  |  | Customer label on device – Laser marking   |
| -TN  |  | Type label neutral   |
| -MZ  |  | Material test certificate – EN10204 3.1  |
| -WT  |  | Factory certification – drink water suitability  |
| -KF  |  | Configuration / Preset   |
| -WK  |  | Factory calibration – calibration certificate  |

Precont® PU4S C V C S S

Stand 02/2018



## 14.3.2 Speed sensor

### IE5390

#### Inductive sensor

IEK31,5-BPKG/V4A/K1/AS

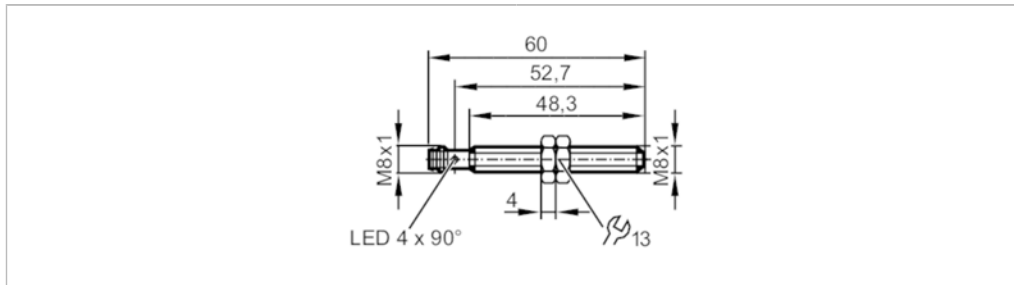

| Product characteristics                              |  |
|--|--|
| Electrical design                                    | PNP  |
| Output function                                      | normally open  |
| Sensing range [mm]                                   | 1.5  |
| Housing  | Threaded type  |
| Dimensions [mm]                                      | M8 x 1 / L = 60  |
| Application  |  |
| System   | gold-plated contacts; correction factor = 1; Magnetic-field immune |
| Magnetic-field immune                                | yes  |
| Max. electromagnetic field immunity [mT]             | 300  |
| Electrical data                                      |  |
| Operating voltage [V]                                | 10...30 DC   |
| Current consumption [mA]                             | < 20   |
| Protection class                                     | III  |
| Reverse polarity protection                          | yes  |
| Outputs  |  |
| Electrical design                                    | PNP  |
| Output function                                      | normally open  |
| Max. voltage drop switching output DC [V]            | 2.5  |
| Permanent current rating of switching output DC [mA] | 100  |
| Switching frequency DC [Hz]                          | 1000   |
| Short-circuit protection                             | yes  |
| Overload protection                                  | yes  |
| Monitoring range                                     |  |
| Sensing range [mm]                                   | 1.5  |
| Real sensing range Sr [mm]                           | 1.5 ± 10 %   |
| Operating distance [mm]                              | 0...1.2  |

## IE5390



### Inductive sensor

IEK31,5-BPKG/V4A/K1/AS

| Accuracy / deviations   |   |                     |
|---|---|---------------------|
| Correction factor   | steel: 1 / stainless steel: 1 / brass: 1 / aluminum: 1 / copper: 1            |                     |
| Hysteresis [% of Sr]  | 1...20  |                     |
| Switch-point drift [% of Sr]  | -10...10  |                     |
| Correction factor = 1   | yes   |                     |
| Operating conditions  |   |                     |
| Ambient temperature [°C]  | -25...70  |                     |
| Protection  | IP 65; IP 67; (with ifm socket duly screwed on)                               |                     |
| Tests / approvals   |   |                     |
| EMC   | EN 61000-4-2 ESD  | 4 kV CD / 8 kV AD   |
|   | EN 61000-4-3 HF radiated  | 10 V/m              |
|   | EN 61000-4-4 Burst  | 2 kV                |
|   | EN 61000-4-6 HF conducted   | 10 V                |
|   | EN 55011  | class B             |
| MTTF [years]  | 544   |                     |
| Mechanical data   |   |                     |
| Weight [g]  | 19.3  |                     |
| Housing   | Threaded type   |                     |
| Mounting  | flush mountable   |                     |
| Dimensions [mm]   | M8 x 1 / L = 60   |                     |
| Thread designation  | M8 x 1  |                     |
| Material  | housing: stainless steel (1.4404 / 316L); sensing face: LCP; lock nuts: brass |                     |
| Displays / operating elements   |   |                     |
| Display   | Switching status  | 4 x 90° LED, yellow |
| Accessories   |   |                     |
| Accessories (supplied)  | lock nuts: 2  |                     |
| Remarks   |   |                     |
| Pack quantity   | 1 pcs.  |                     |
| Electrical connection - plug  |   |                     |
| Connector: 1 x M8; Locking: snap-fit ; Contacts: gold-plated                        |   |                     |
|  |   |                     |

## IE5390

### Inductive sensor

IEK31,5-BPKGIV4A/K1/AS



#### Connection

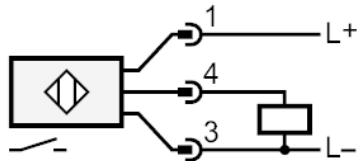

## 14.4 Service plan

### Service plan

All maintenance activities carried out to the maintenance schedule → *10.4 Maintenance intervals* must be entered in the service plan.

The guarantee will expire if the maintenance and service work is not carried out and documented.

| Maintenance work | Date | Signature |
|------------------|------|-----------|
|                  |      |           |
|                  |      |           |
|                  |      |           |
|                  |      |           |
|                  |      |           |
|                  |      |           |
|                  |      |           |
|                  |      |           |
|                  |      |           |
|                  |      |           |
|                  |      |           |
|                  |      |           |
|                  |      |           |
|                  |      |           |
|                  |      |           |
|                  |      |           |
|                  |      |           |
|                  |      |           |
|                  |      |           |
|                  |      |           |
|                  |      |           |
|                  |      |           |