



Operating Instructions

Rotary Lobe Pump

VX100Q

ENGINEERED TO WORK

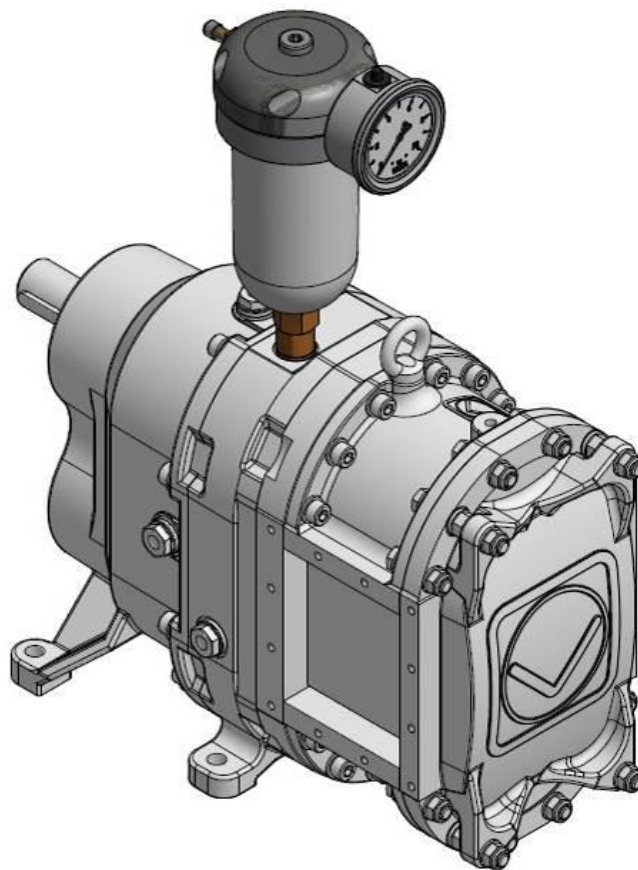

Original operating instructions

Issuer

Vogelsang GmbH & Co. KG
Holthöge 10-14
49632 Essen/Oldb.

Phone: +49 54 34 83 0
Fax: +49 54 34 83 10

www.vogelsang.info
info@vogelsang.info

In the absence of express, written authorisation from the issuer, the reproduction or partial reproduction of this document in any form is prohibited.

We reserve the right to make technical modifications to the diagrams and information presented in this document in the event that such modifications become necessary for the enhancement of the machine.

© 2018 Vogelsang GmbH & Co. KG

Registered trademarks of Vogelsang

In selected countries, Vogelsang[®], RotaCut[®], HiFlo[®], ACC[®], CFC[®], BioCrack[®], XTill[®], EnergyJet[®], BioCut[®], CC-Serie[®], PreMix[®], ProTerra[®], VarioCrop[®] and XRipper[®] are registered trademarks of Vogelsang GmbH & Co. KG, Essen/Oldb., Germany.

All rights reserved, including graphics and images.

The registered trademarks are not always designated with an [®] symbol in this document.

Dear customer,

in every one of our products, you will see the entirety of our competence and our power of innovation at work. Each product is developed and built so that you can work more successfully.

We call it quite simply: ENGINEERED TO WORK

If you want to know more about our company or put forward requests or suggestions, a wealth of information can be found at www.vogelsang.info

| | |
|--|-----------|
| Issuer | 2 |
| Table of contents | 3 |
| 1 User information | 6 |
| 1.1 Using the operating instructions..... | 6 |
| 1.2 Presentation convention..... | 6 |
| 1.3 Explanation of symbols..... | 7 |
| 1.4 Machine versions described here..... | 9 |
| 2 EC declaration | 10 |
| 3 Specifications | 11 |
| 3.1 Material description for rotary lobes..... | 12 |
| 3.2 InjectionSystem..... | 13 |
| 3.3 Name plate..... | 14 |
| 4 Safety | 15 |
| 4.1 Operator's responsibilities..... | 15 |
| 4.2 Personnel qualification..... | 16 |
| 4.3 Fields of activity..... | 16 |
| 4.4 Intended use..... | 17 |
| 4.5 General safety notes..... | 17 |
| 4.6 Main switch, maintenance and repair switch..... | 18 |
| 4.6.1 EMERGENCY STOP shutdown (main switch)..... | 18 |
| 4.6.2 Maintenance and repair switch..... | 18 |
| 4.7 Warning and safety stickers on the machine..... | 19 |
| 5 Transport, storage | 20 |
| 5.1 Transport..... | 20 |
| 5.2 Storage..... | 21 |
| 6 Assembly | 22 |
| 6.1 Installation in pipe systems..... | 22 |
| 6.2 Pipes..... | 23 |
| 6.3 Direction of flow..... | 25 |
| 6.3.1 Pump with motor drive..... | 25 |
| 6.3.2 Pump systems..... | 25 |
| 6.3.3 Pumps with InjectionSystem..... | 26 |
| 6.4 Pump connection..... | 27 |
| 6.5 Base, support surface for machine..... | 28 |
| 6.5.1 Machine without base..... | 28 |
| 6.5.2 Machine and motor on base C (with coupling)..... | 28 |
| 6.5.3 Coupling orientation..... | 29 |
| 6.5.4 Coupling guard..... | 30 |
| 6.5.5 Machine and motor on base B (belt drive)..... | 30 |
| 6.5.6 Machine on hand cart..... | 31 |
| 6.5.7 Machine on three-point base..... | 31 |
| 6.6 Drive..... | 32 |
| 6.6.1 Electric drive..... | 32 |
| 6.6.2 Hydraulic drive..... | 34 |

| | | |
|-----------|--|-----------|
| 6.6.3 | Combustion engine drive | 35 |
| 6.7 | System control | 36 |
| 7 | Start-up | 37 |
| 8 | Maintenance..... | 39 |
| 8.1 | Buffer chamber..... | 39 |
| 8.1.1 | Pressurisable buffer fluid tank | 40 |
| 8.1.2 | Depressurised quenching fluid tank | 43 |
| 8.1.3 | Pressure valve | 44 |
| 8.1.4 | Plugs | 44 |
| 8.1.5 | Buffer or quenching fluid - type | 45 |
| 8.1.6 | Buffer or quenching fluid - quantity..... | 45 |
| 8.1.7 | Buffer or quenching fluid - inspection and change | 45 |
| 8.2 | Draining and cleaning the buffer chamber | 46 |
| 8.3 | "Dry buffer chamber" sealing system | 47 |
| 8.4 | Circulation system on the cartridge mechanical seal | 48 |
| 8.5 | Gearbox..... | 49 |
| 8.5.1 | Gear oil - grade | 49 |
| 8.5.2 | Gear oil - quantity | 49 |
| 8.5.3 | Gear oil – inspection and change..... | 49 |
| 8.6 | Oils..... | 51 |
| 9 | Repair..... | 54 |
| 9.1 | Conversion and spare parts | 54 |
| 9.2 | Opening the Q cover..... | 55 |
| 9.3 | Rotary lobe change | 56 |
| 9.4 | How the lobe puller works | 58 |
| 9.5 | Change of wear plates | 60 |
| 9.6 | Change of cartridge mechanical seal | 61 |
| 9.7 | Closing the Q cover | 63 |
| 9.8 | Adjusting of pump housing segments | 63 |
| 9.9 | Reducing the starting torque | 64 |
| 10 | Troubleshooting | 65 |
| 10.1 | Troubleshooting | 65 |
| 10.2 | Help..... | 65 |
| 11 | Putting out of operation and disposal | 67 |
| 12 | Maintenance plan..... | 69 |
| 12.1 | Maintenance instructions | 69 |
| 12.2 | Maintenance intervals | 69 |
| 12.3 | Additional maintenance intervals for pumps with belt drive | 70 |
| 13 | Service plan | 71 |

Table of figures

Fig. 1: InjectionSystem 13

Fig. 2: Name plate 14

Fig. 3: Positions of the warning and safety labels 19

Fig. 4: Transport aids 20

Fig. 5: Installation variants 22

Fig. 6: Long suction lines 24

Fig. 7: Flow direction with motor drive 25

Fig. 8: Flow direction with pump units 25

Fig. 9: Tightening sequence 27

Fig. 10: Orientation procedure 29

Fig. 11: Vent screw on the gearbox (removing the seal) 33

Fig. 12: Buffer fluid tank 40

Fig. 13: Filling/draining the buffer chamber 41

Fig. 14: Pump with quenching fluid tank 43

Fig. 15: Pump with pressure valve 44

Fig. 16: Installation example - dry buffer chamber 47

Fig. 17: Flushing operation 48

Fig. 18: Gear oil change 50

Fig. 19: Opening/closing the Q cover 55

Fig. 20: Rotary lobe change 56

Fig. 21: HiFlo and HiFloplus arrangement 57

Fig. 22: Lobe puller components 58

Fig. 23: Hooking puller arm into lobe 59

Fig. 24 Pulling out the lobes with lobe puller 59

Fig. 25: Installation position of the curved wear plates 60

Fig. 26: Cartridge mechanical seal on the gearbox 62

Fig. 27: Adjustment of pump housing segments 63

Relevant documents

- Dimension sheet / drawing
- Characteristic line
- EC declaration of conformity

Optional:

- Technical information on drive system
- Technical information on safety devices

Please read and adhere to the information and instructions in the relevant documents.

1 User information

1.1 Using the operating instructions

These instructions contain information concerning operating elements, handling, start-up and maintenance and repair work, as well as the relevant specifications.

The operating instructions are a component of the machine.



IMPORTANT READ CAREFULLY BEFORE USE

Read the operating instructions thoroughly. All of the points presented in these instructions must be understood and observed by those persons responsible for the installation, operation, maintenance and repair of the machine.



Vogelsang does not accept any liability for damage resulting from failure to comply with these operating instructions.

KEEP FOR FUTURE REFERENCE

Please keep the manual ready at hand to ensure easy access to the necessary information at all times.

Additional copies of the manual are available upon request.  

1.2 Presentation convention

| Presentation | Meaning |
|---|--|
| • | Listing |
| – | Sublisting |
| 1. 2. | Carry out these actions in the described sequence |
| → Fig. "Caption" | Reference to a figure for additional information |
| → Chapter "Chapter heading" | Reference to a chapter for additional information |
| → Table "Table caption" | Reference to a table for additional information |
|  "Relevant document" | Reference to a document for additional information |
|   Technical support | Contact our technical support |

1.3 Explanation of symbols

The following symbols and signal words are used in this manual:

- 1 If personal protective equipment is needed to work with and on the machine, that is indicated by the following symbols:



Indicates that protective gloves must be worn for subsequent tasks.



Indicates that protective goggles must be worn for subsequent tasks.



Indicates that safety shoes must be worn for subsequent tasks.

2 This symbol draws attention to the use of tools:



Tools, mounting devices and resources required for the following work tasks.

3 General notices and information about environmental protection are marked by these symbols:



NOTE

Refers to further information and useful notes.



ENVIRONMENTAL PROTECTION

Refers to measures to be observed to prevent damage to the environment.

4 Safety notes are introduced by these symbols and words:



CAUTION

Refers to a dangerous situation in which failure to comply with the safety note could result in light injuries.



WARNING

Refers to a dangerous situation in which failure to comply with the safety note could result in death or serious injuries.



DANGER

Refers to an (extremely) dangerous situation in which failure to comply with the safety note will result in death or serious injuries.



RISK OF ELECTRIC SHOCK

Touching live parts leads to dangerous electrocution.
This can result in electric shock, burns or death.



ATTENTION

Refers to possible damage to machinery or property as a result of failure to comply with this note.

1.4 Machine versions described here

In → **Chapter** "Installation", the following optional machine versions are described:

| Machine version | Chapter reference |
|--|--|
| • With or without pump connectors | → Chapter "Pump connector" |
| • On a base or without a base | → Chapter "Base, support surface for machine" |
| • With the following drive options: <ul style="list-style-type: none">– Electric drive– Hydraulic drive– PTO drive– Combustion engine drive | → Chapter "Drive" |
| • With or without system control | → Chapter "System control" |

The machines listed in these operating instructions are subject to the Machinery Directive (2006/42/EC), see sample printout in → **Chapter** "EC declaration".

2 EC declaration

(sample printout)

EC Declaration of conformity

According to Machinery Directive 2006/42/EC; annex II A

Manufacturer: Vogelsang GmbH & Co. KG
Holthöge 10-14
49632 Essen/Oldb.
GERMANY

We hereby declare that the machine described below meets the basic health and safety requirements of the Machinery Directive 2006/42/EC in its design and construction and in the version marketed by us.
If a change is made to the machine without our agreement, this declaration loses its validity.

Product: Rotary lobe pump

Applied harmonised standards:

DIN EN ISO 12100:2010

DIN EN 809:2012

The person or entity authorised to compile the technical documentation is:
Vogelsang GmbH & Co. KG; Holthöge 10-14; 49632 Essen/Oldb., GERMANY



49632 Essen, 2017-07-03



Harald Vogelsang (Managing Director)

3 Specifications

| VX100Q series | Max. rotation speed: 1000 min ⁻¹ | | Max. differential pressure** | | Theoretical torque*** | | |
|---------------|---|--------------------------|------------------------------|-------|-----------------------|------|--------------------|
| | Displacement | Theoretical volume flow* | | | | | |
| Size | [l] | [l/min] | [m ³ /h] | [bar] | Aluminium**** [bar] | [Nm] | Aluminium**** [Nm] |
| 45 | 0.30 | 300 | 18 | 10 | 7 | 65 | 50 |
| 64 | 0.43 | 430 | 26 | 9 | 5 | 80 | 55 |
| 90 | 0.60 | 600 | 36 | 7 | 3 | 90 | 55 |
| 128 | 0.85 | 850 | 51 | 4 | 2 | 85 | 55 |

- * All values refer to the theoretical volume flow. The actual volume flow is lower; it depends on the operating conditions in each case.
- ** Valid only for short operation times. For continuous operation, please contact our service department.  
The service life of the lobes is reduced by high temperatures, especially in combination with high pressure. Observe the material-specific differential pressure limits → **Notice**.
- *** Theoretical operating torque with max. differential pressure and water, designed for NBR elastomers.
- **** For pumps with aluminium gearbox housing, the differential pressure/torque is reduced.



ATTENTION

Speed reduction for highly viscous media

When using the pump for a highly viscous medium, the pump speed must be reduced according to the material's viscosity, to prevent the intake flow from breaking off on the suction side (cavitation protection).

Material-specific differential pressure limits

With some materials, premature wear is likely if the pump pressure is too high. Observe the following material-specific differential pressure limits.

FPM lobes: max. 6 bar

Steel or stainless steel lobes: Please consult our service department  

Cartridge mechanical seal made of Duronit: max. 10 bar



Maximum free passage: Ø 20 mm

Weights and dimensions

For the machine's weight and dimension specifications, see  "Dimension sheet"

3.1 Material description for rotary lobes

| Marking on the rotary lobe | Material | Elastomer-based | Resistant up to | Pump medium | Characteristics |
|----------------------------|------------------------------------|---|-------------------|---|---|
| NBR | NBR | Nitrile butadiene rubber | 80 °C * | Sewage sludge, petrol, oil, grease, diesel oil, spindle oil | Oil-resistant |
| NBR | NBR, white | Nitrile butadiene rubber | 80 °C * | Oil, butter, linseed and olive oil, lard | Food grade |
| SBR | SBR | Styrene butadiene rubber | 60 °C | Liquid manure | Wear-resistant |
| SL | EPDM-SL (EPDM-Sew age-Line) | Ethylene propylene diene M-class rubber | 80 °C * | Water, liquid manure, sewage sludge, biogas substrate | Not oil and grease resistant, water resistant, steam resistant |
| AL | EPDM-AL (EPDM-Aqua-Line) | Ethylene propylene diene M-class rubber | 80 °C * | Drinking water | Drinking water approved **, not oil or grease-resistant, water-resistant, steam-resistant |
| EPDM | EPDM, white | Ethylene propylene diene M-class rubber | 80 °C * | Water, mash, slightly acidic products | Food grade |
| PU | PU (Werobust) | Polyurethane vulcanised | 50 °C | Abrasive medium | Wear-resistant |
| PUR | PUR | Polyurethane cast | 80 °C | Abrasive medium | Highly wear-resistant |
| CSM | CSM (Hypalon) | Chloro-sulfonyl polyethylene rubber | 80 °C * | Petrol, oil, acids, alkali solutions | Wear-resistant, acid-resistant and alkali-resistant |
| FPM | FPM | Fluorocarbon gum | 80 °C * | Solvents, salt water, oil, petrol, acids | Acid-resistant and alkali-resistant |
| | Steel lobes (pure material) | 1.4571 | 150 °C 200 °C* | Pure medium Chemistry | High temperatures, high chemical resistance |
| | Steel rotary lobes (pure material) | C45 nitrided | 150 °C 200 °C* | Pure medium petrochemical | High temperatures, chemical resistance |

Table: Material description

* consult Vogelsang in the event of the combination of "high differential pressure and high temperatures" ☎️✉️

** drinking water approvals: KTW, DVGW-Arbeitsblatt, W 270, WRAS, BELAQUA



Please consult us ☎️✉️

- If you require combinations with high differential pressure and high temperatures – (see * in → Table "Material description").
- With solid material lobes with media containing foreign matter
- If you should discover discrepancies or if precise specifications have not been provided for the medium

3.2 InjectionSystem

InjectionSystem refers to a special type of pump housing segment for filling optimisation.

The InjectionSystem injects foreign matter directly into the delivery spaces in the pump chamber as they open, conveying them on to the pump outlet (for improved foreign matter protection).

In addition, an InjectionSystem also improves the internal sealing of the pump.

Injection S (Symmetrical InjectionSystem)

The filling optimisation structure is located at the pump inlet and at the pump outlet. This allows flow in either direction.

Injection S provides improved pump sealing (with more seal lines), thus allowing higher volumetric efficiency.

Injection A (Asymmetrical InjectionSystem)

The filling optimisation structure is located at the pump inlet only. Therefore, the direction of flow is set in advance. A brief reverse operation is possible.

Injection A provides improved foreign matter protection with low-viscosity fluids and a high proportion of foreign matter.

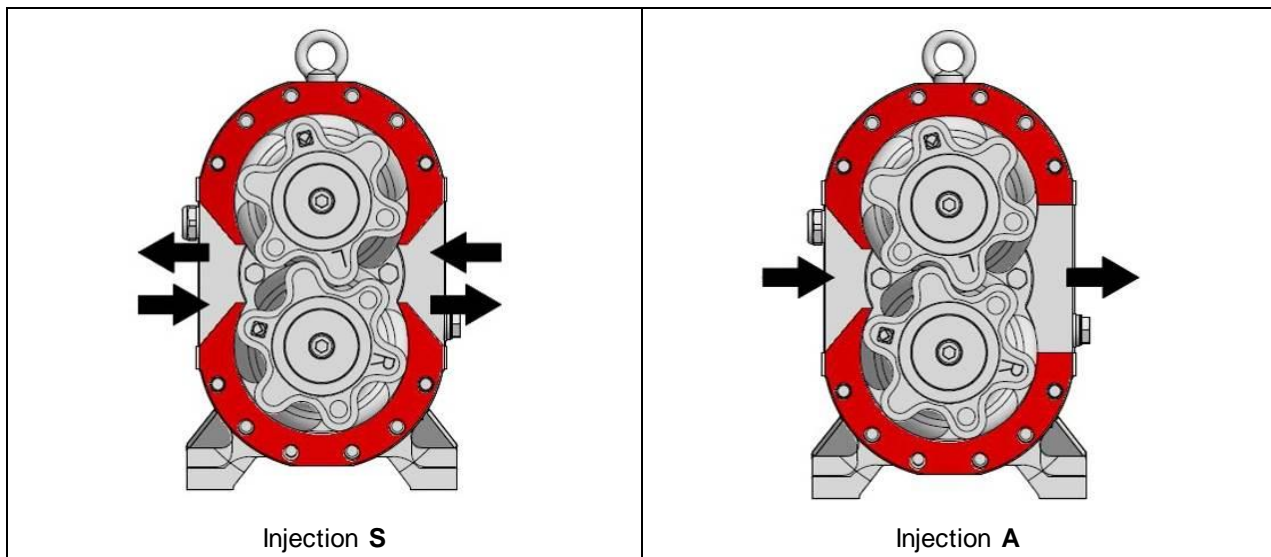

Fig. 1: InjectionSystem

3.3 Name plate

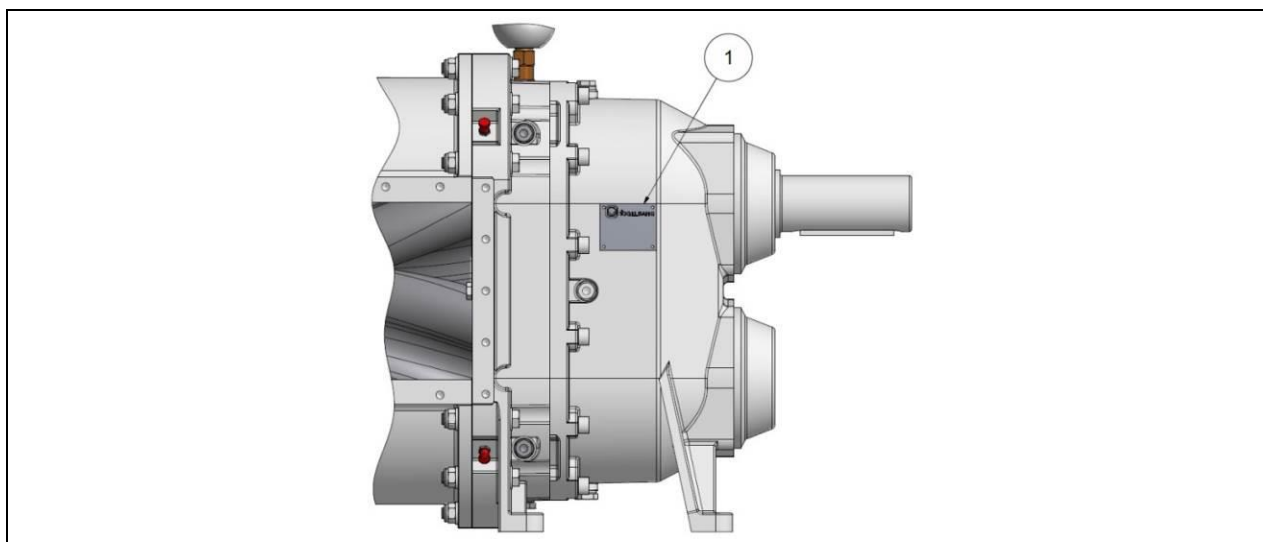



Fig. 2: Name plate

The name plate (1) contains the following details:

| | |
|--|------------------------|
|  VOGELSANG | |
| Product | QR-Code |
| Design (series) | |
| Serial number | CE Year of manufacture |
| | Weight |
| Part number | |
| Address of Vogelsang, GERMANY | |

4 Safety

This section gives you an overview of important safety aspects needed to ensure optimum protection of personnel and to ensure safe and trouble-free operation.

Failure to comply with the instructions and safety information specified in this manual may result in serious hazards.

In the event of any abnormalities and/or signs relating to the safety of the product supplied by Vogelsang, please contact us without delay via:

produktsicherheit@vogelsang.info

4.1 Operator's responsibilities

The machine is used commercially. The operator of the machine is therefore subject to the statutory occupational safety regulations.

In addition to the safety information provided in this manual, the relevant safety, accident prevention and environmental protection requirements for the area in which the machine is used must be complied with.

The following applies in particular:

- The operator shall ensure that all persons who handle the machine have read and understood this manual. If necessary, the operator shall train personnel and inform them of possible hazards. To help keep track of training, we recommend creating a training log.
- The operator shall clearly regulate and define responsibilities for transport, installation, start-up, operation, maintenance, repair, cleaning, troubleshooting, shutdown and disposal.
- The operator must take appropriate safety measures as required by the nature of the media, such as acidic or alkaline media, or high media temperatures > 60 °C.

The operator is responsible for ensuring that the machine is always in perfect technical condition.

The following therefore applies:

- The operator shall ensure that maintenance intervals described in this manual are complied with and are documented in the service plan.
- The operator shall have all safety devices checked at regular intervals to ensure that they are fully functioning and complete.

4.2 Personnel qualification

Instructed person

Has been instructed by the operator to perform the tasks for which the instructed person is responsible and has been informed of possible hazards in the event of improper behaviour.

Qualified technical personnel

Are able, due to their specialist training, skills, experience and knowledge of the relevant regulations, to perform the work for which they are responsible, and are able to identify and avoid possible hazards independently.

Qualified electrician

Is able, due to his or her specialist training, skills, experience and knowledge of the relevant standards and regulations, to perform work on electrical systems, and is able to identify and avoid possible hazards independently.

Handling the machine improperly can result in serious injuries and property damage.

For this reason, all activities must be performed by qualified personnel only.

Only persons who can be expected to perform their work reliably shall be permitted as personnel. Persons whose ability to respond is impaired, for example due to drugs, alcohol or medication, are not approved.

4.3 Fields of activity

- The activities described in this manual may be performed by instructed persons unless explicit mention is made of a special qualification that is necessary.
- If activities may only be performed by qualified technical personnel, this fact will be clearly stated in this manual. Safety devices may only be connected and checked by qualified technical personnel.
- Electrical work and work on the electrical system may only be performed by qualified electricians.

Vogelsang must always be consulted prior to any system-specific activities that are not described in this manual. ☎️✉️

Training in the activities described in this manual may be provided by Vogelsang on request. ☎️✉️

4.4 Intended use

The Vogelsang rotary lobe pump (hereafter referred to as "pump" or "machine") is a self-priming positive displacement pump for pumping fluids ranging from water-like to highly viscous (hereafter referred to as "medium").

The medium may be chemically neutral, acidic or alkaline. It may be loaded with solid particles and/or gas. The pump is designed to pump the medium specified by the customer.

For a different medium or if the pump is not designed for a particular application, it has to be checked whether the characteristics of the pump are suitable for the pump medium in terms of the material and fluid group. In some cases the pump or the pump connectors must be reconfigured.

In addition to these specifications, the specifications in → **Chap. "Specifications"** must be complied with as well.

Any other use is contrary to the intended purpose. Vogelsang is not liable for any damage resulting from incorrect use.

Foreseeable misuse:

The machine is **NOT** intended for the following uses:

- Potentially explosive atmospheres
- Operation subject to cavitation
- Use in the food industry without checking the specific hygiene requirements for the pump

4.5 General safety notes



WARNING

Risk of injury (catching, crushing, collision) due to rotating rotary lobes if the machine starts up unexpectedly!

Before starting maintenance and repair work (opening covers, disassembling connectors) and before troubleshooting, switch the machine off and secure it against being switched on again.



WARNING

Risk of injury from medium escaping under high pressure!

If the maximum differential pressure is exceeded, machine parts may burst and medium may spray out.

- The maximum differential pressure must not be exceeded → **Chap. "Specifications"**.
- Observe and implement the recommendations in → **Chap. "Installation in pipes"**.
- Protect the machine or system against overpressure. For example, the following monitoring devices can be used:
 - A current limiter on the motor
 - A pressure relief valve
 - Cut-off with a pressure control switch
 - An overload coupling



WARNING

Skin and eye irritation caused by contact with hazardous working materials or media!

All work on the machine can lead to contact with working materials or media.



- Personnel must wear suitable protective clothing.
- The operator must inform his or her staff about any potentially hazardous substances in working materials or media.



CAUTION

Risk of burning due to exposed host surfaces!

If the medium temperature is greater than 60 °C or the pump experiences dry running, the pump housing, the connectors or the pipes can become very hot.

At high speeds or high differential pressure, the gearbox housing can also become very hot.

- Avoid (accidental) contact with hot surfaces.
- Avoid dry running of the pump, e.g. by means of dry running protection via
 - Temperature monitor
 - Level measurement
 - Flow measurement



ATTENTION

Risk of frost!

To protect the pump against damage caused by frozen medium, drain it when there is a risk of frost.

- Drain the pump by running the pump in either direction (forward or reverse), until all liquid is drained out of the pump. You can use drain cocks in the connectors to do this.
- For complete emptying of the pump chamber, remove the Q cover, → Chapter "Opening the Q cover".
- Before start-up, refill with fluid.

4.6 Main switch, maintenance and repair switch

All-pole disconnection must be provided for the main switch and maintenance and repair switch.

4.6.1 EMERGENCY STOP shutdown (main switch)

For shutdown in the event of an emergency, an emergency stop must be present and freely accessible at all times.

4.6.2 Maintenance and repair switch

To safely exclude the possibility of unexpected machine start-up, a maintenance and repair switch must be installed in the immediate vicinity of the electric drive so that the electrical power can be safely isolated for maintenance purposes.

The maintenance and repair switch must be secured in its OFF position to prevent it being switched back on again, using a padlock for example.



WARNING

Qualified technical personnel must connect and check the safety devices on a regular basis for proper function, especially after performing maintenance and repair work and before start-up.

4.7 Warning and safety stickers on the machine

Warning and safety stickers on the machine

- provide important information for the safe operation of the machine. Observing the stickers is for the safety of persons who work with and on the machine.
- must remain legible, remove any contamination, if required.
- may not be removed and must be replaced immediately if damaged or lost.

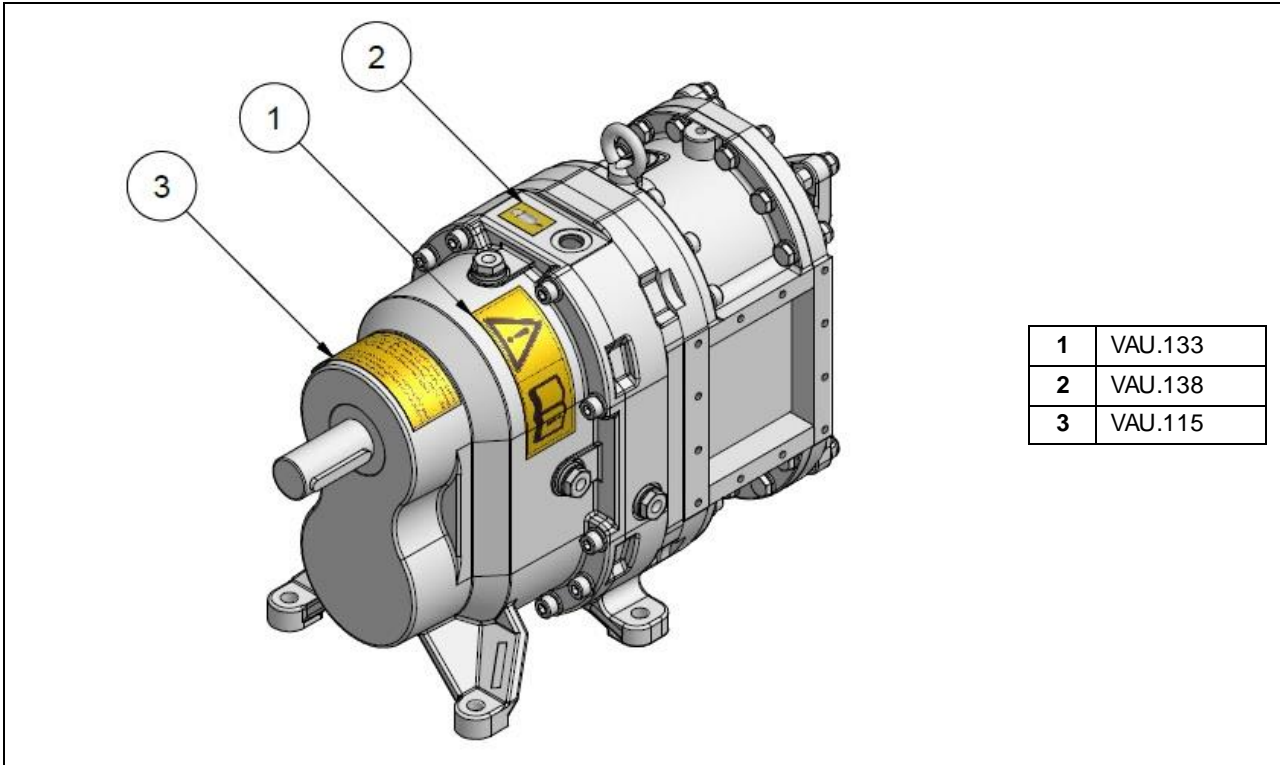

| | |
|---|---------|
| 1 | VAU.133 |
| 2 | VAU.138 |
| 3 | VAU.115 |

Fig. 3: Positions of the warning and safety labels

(example only, the position of the stickers can vary depending on the size)

| | | |
|---------|--|---|
| VAU.133 | | Before machine start-up, operating instructions must be read! |
| VAU.138 | | Buffer or quenching fluid tank |
| VAU.115 | | (Only used for pumps with a mechanical seal consisting of the material combination SiSiC-SiSiC) (To avoid adhesion of the mechanical seal faces this pump needs to be rotated (at least one revolution) every two months when not in service!) |

5 Transport, storage

5.1 Transport

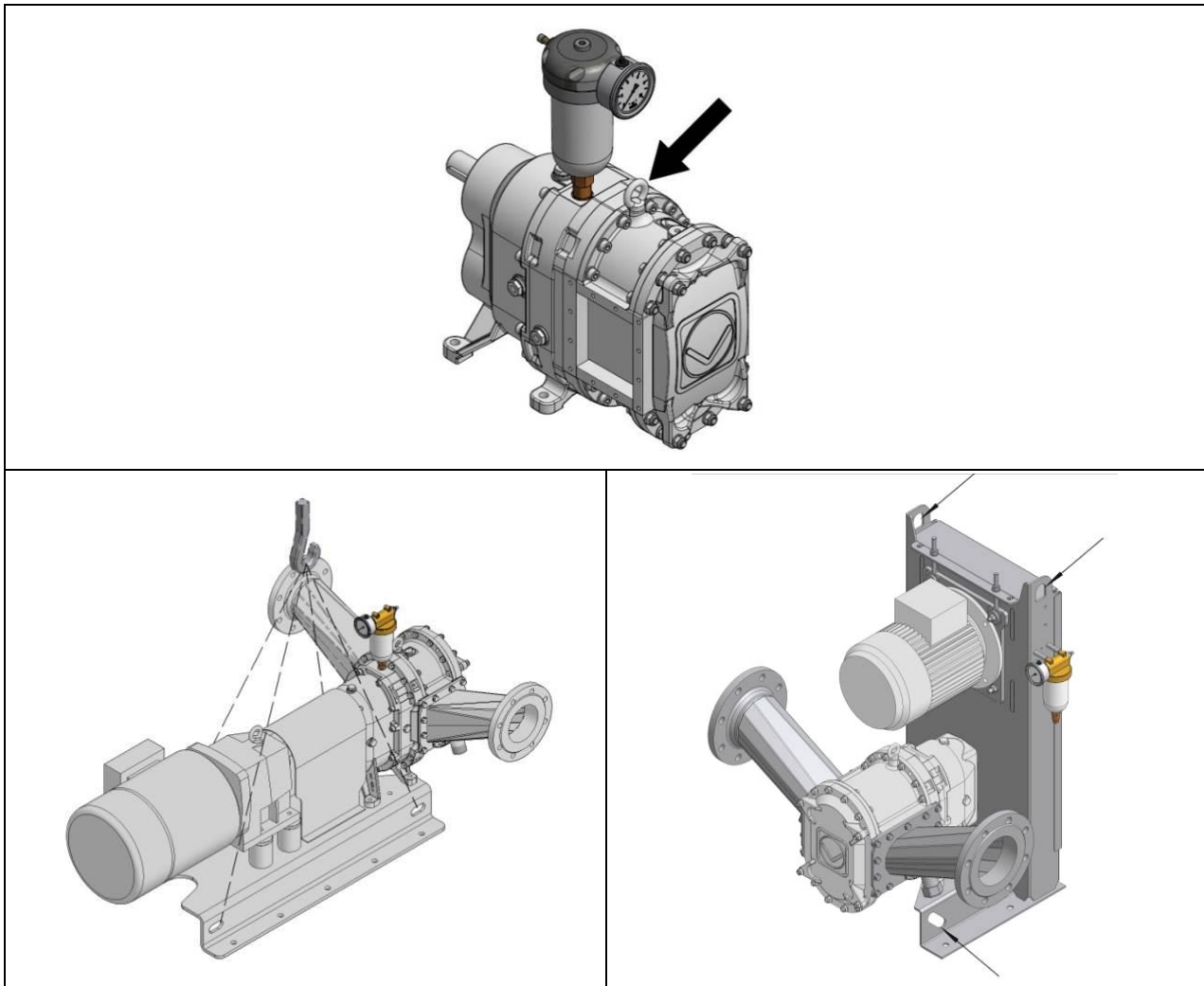

Fig. 4: Transport aids



WARNING

Risk of crushing or concussion due to falling machine!

The machine may start to sway or topple when it is transported, loaded or set down. To ensure safe transport, note the following:

- Loading and transporting may only be carried out by qualified technical personnel. In other words: The operator of a crane or forklift must be able to show an appropriate authorisation.
- Cranes and hoists as well as forklifts must be designed for the weight of the transport units.
- Standing under raised loads is prohibited. Have people leave the danger area.
- Permissible transport options for the machine: suspended, or bolted onto a Euro-pallet.
- In the case of suspended transport of the machine:
 - Remove the buffer fluid tank or quenching fluid tank before transport.
 - Use the lifting eye bolts and/or lifting lugs fitted for hoisting gear and securely fasten the lifting tackle.
 - Use the lifting eye bolts **on the machine** only for lifting and transporting the machine **without** attachments or system components (e.g. motor, connectors or base).

5.2 Storage

Complete pumps, cartridge mechanical seals, individual O-rings and seal components

If not stored and handled properly, the physical characteristics of products made of rubber may change. Possible consequences include excessive hardening, softening, lasting deformation, peeling, cracking or other surface damage.

Long-term storage is possible under the following conditions (longer than 6 months to a maximum of 5 years):

- The storage area should be dry (relative humidity under 65%) and the temperature should be between 5 °C and 30 °C.
- The pump chamber can be sealed with a preservative that is compatible with the material of the lobes and gaskets.
- The products should be protected against light, especially direct sunlight and strong artificial light with a high ultraviolet component.

After a storage period of five years or more and before start-up we recommend:

- Checking and renewing (if necessary) all wetted gaskets and lobes
- Changing the gear oil and the buffer or quenching fluid

For pumps with a mechanical seal that has the mating materials SiC-SiC, the shaft must be turned (at least one revolution) every two months so that the sealing surfaces of the mechanical seal rings do not stick together.

6 Assembly

6.1 Installation in pipe systems

- The pump may be installed in an upright, horizontal, vertical or suspended position → Fig. "Installation variants".
 - With a horizontal installation, the inlet must be at the bottom and the outlet at the top.
- When installing the pump, ensure that there is easy access for maintenance work. If the screw plugs for draining the gear oil and buffer or quenching fluid are not easy to reach, discharge lines may be used (part nos. PBT.013 and/or PBT.014).
- Ensure that the pump is installed tension-free and that no tension can develop during operation either.

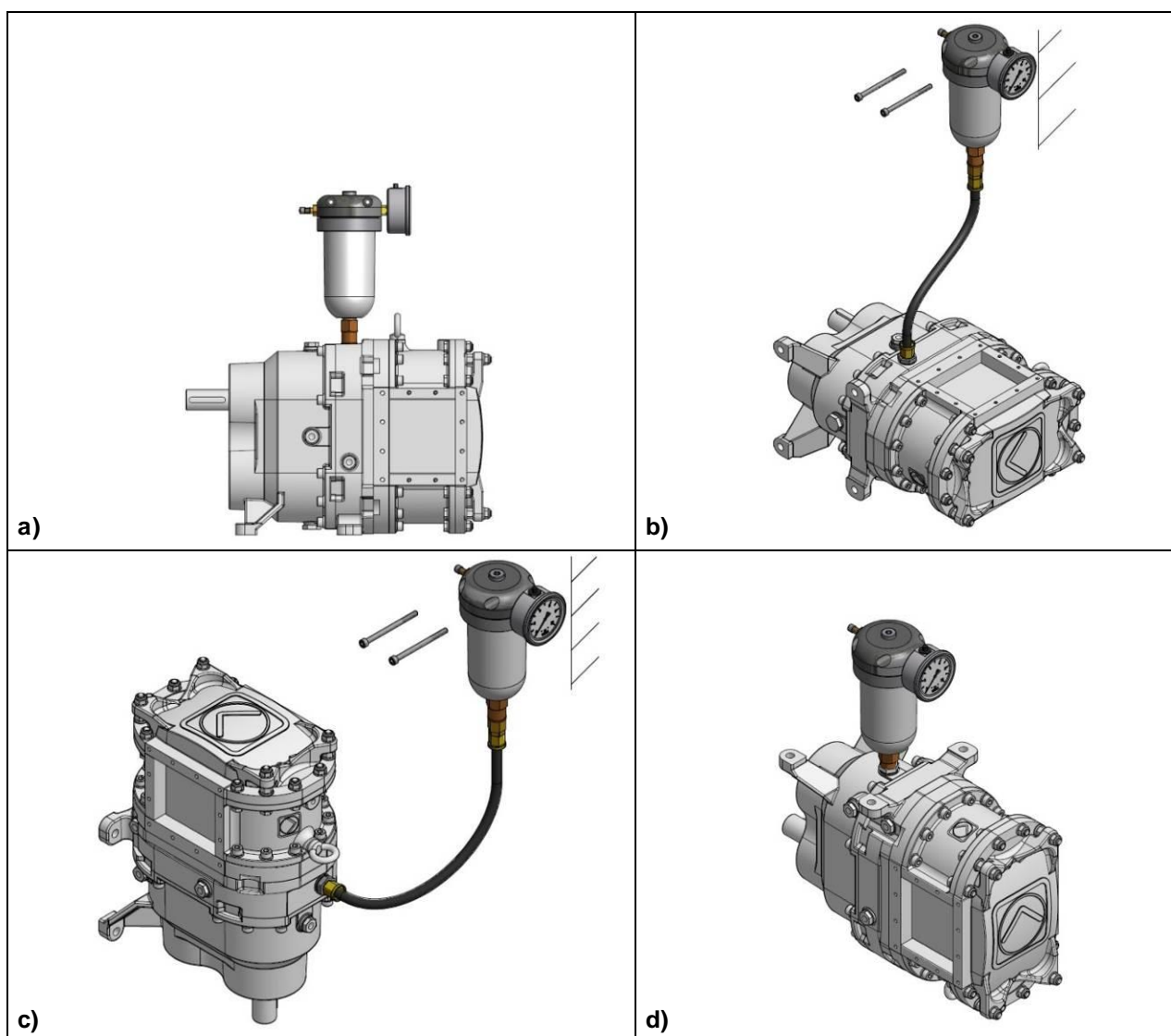

Fig. 5: Installation variants

- | | |
|--|---------------|
| a) upright | b) horizontal |
| c) vertical (fix the buffer fluid tank in place pointing upwards and above the buffer chamber) | d) suspended |

6.2 Pipes

- Only use the pipe diameters, wall thicknesses and materials recommended by us or by our representatives. The sealing material must be compatible with the medium.
- Position the pressure and suction connections pointing upwards. This will ensure that the fluid remains in the pump after it is switched off.
- Keep the pipe as free as possible from foreign matter (stones, wood residues, etc.) in order to prevent increased wear on rotary lobes and housing.



ATTENTION

Hazard risk due to closed pipes!

Pumping may never take place against a closed pipe. The pump shaft seal or even the pump housing or the pipe could be damaged or destroyed by the resulting high pressure. A pressure monitoring system is optionally available from us (configured for the weakest member). ☎️✉️



WARNING

Risk of injury from medium escaping under high pressure!

If the maximum pressure is exceeded, → Chapter "Specifications", parts may burst and the pumped medium may be expelled under high pressure.

- Follow the recommendations for pipes. Only use high-pressure pipes on the discharge side:
 - **Up to** nominal diameter DN 150 - PN 16 (bar) pipes
 - **Above** nominal diameter 200 - PN 10 (bar) pipes, except when the discharge pressure of the pump unit is ≥ 10 bar

If you are uncertain about anything, please contact us. ☎️✉️

- During downtimes and periods of hot weather, fermentation may occur in closed pipes. The resulting gas can result in a significant pressure increase that can damage the pump or pump unit and cause the injuries mentioned above. Therefore, ensure that no medium is left in the pump.
- Attention – if a connector **with a sight glass** is installed on the suction side:
The pressure must not exceed **max. 2 bar** during reverse pumping → Fig. "Flow direction with pump units".



ATTENTION

To protect from high pressure losses and cavitation, heed the advice for laying the suction lines:

- The maximum suction height is 8 m. This is the maximum distance between the lowest and highest points of the suction pipe. Observe NPSH.
- Suction lines whose diameter is too small may restrict the suction capability of the pump. Caution, risk of cavitation!
If the diameter of the suction pipe is too small, the maximum suction height will be reduced by the loss of pressure due to pipe friction. Contact us for a calculation ☎️✉️.
- Suction lines over 30 m must be laid with a slope of at least $2 \times \text{pipe diameter}$ in the direction of flow, ensuring that the pipeline can never run dry → **Fig. "Long suction lines"**.

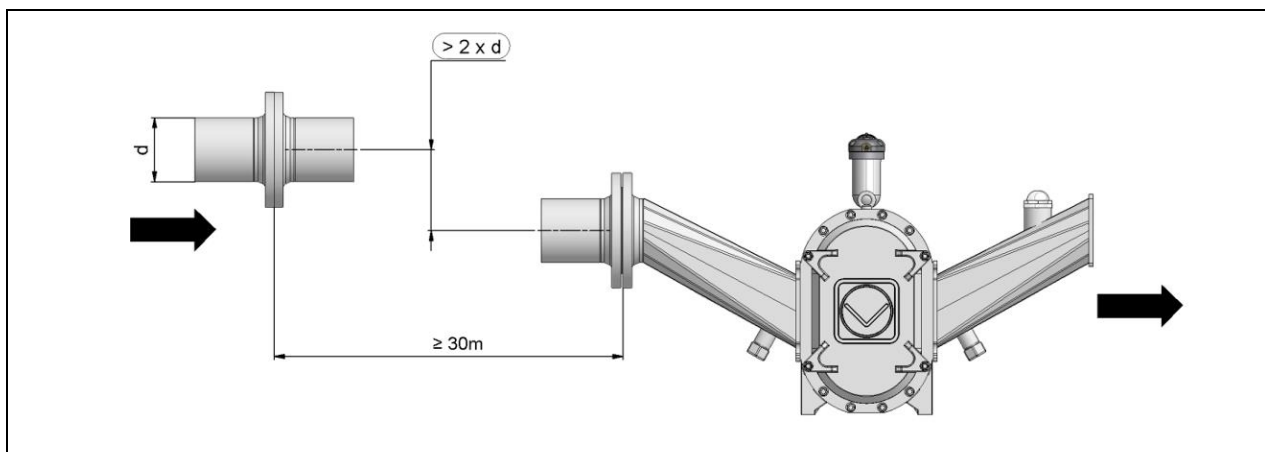

Fig. 6: Long suction lines

6.3 Direction of flow

The pump is suited for both flow directions.

Please observe the following machine and safety exceptions in which the flow direction is predefined:

- Installation in pipes with automatic check valves → Chapter "Pump units"
- Injection A → Chapter "InjectionSystem"

6.3.1 Pump with motor drive

If you are using motor-driven pumps with one drive shaft, the flow direction is selected by determining the direction of rotation of the drive motor, such as an electric motor or hydraulic motor.

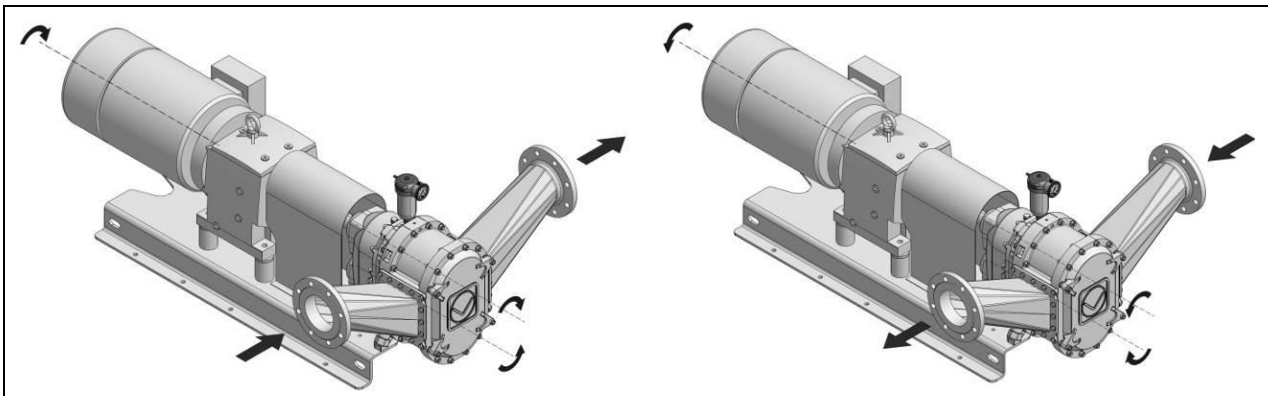

Fig. 7: Flow direction with motor drive

6.3.2 Pump systems

The pressure and suction sides are rigidly defined by the rotation of the pumps. When there are suction difficulties, it is possible to draw in through the discharge side. A reversal of the flow direction is not possible if the pipelines are protected by automatic check valves.



WARNING

Risk of injury from medium escaping under high pressure!

If a connector has a **sight glass**, the sight glass may burst if the pressure is too high.

A connector with a sight glass must be installed **on the suction side**. The pressure may not exceed **max. 2 bar** during reverse pumping.

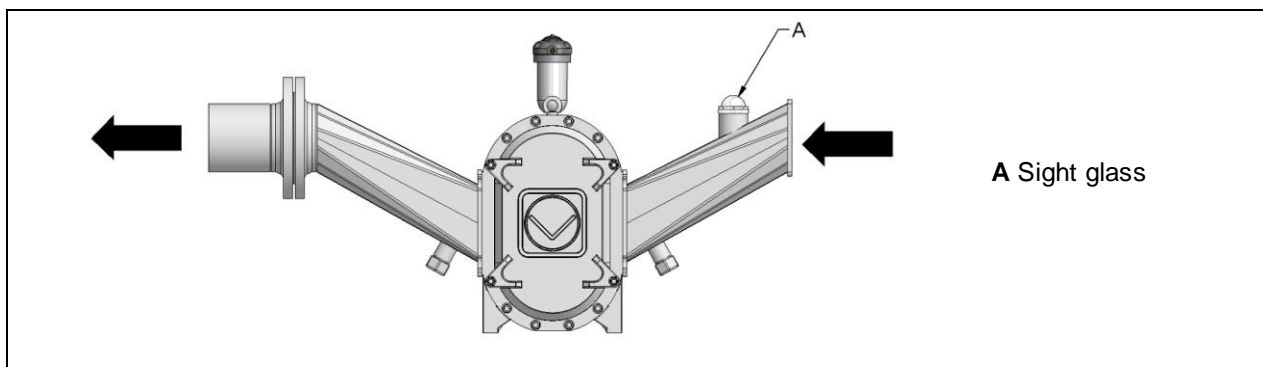

Fig. 8: Flow direction with pump units

6.3.3 Pumps with InjectionSystem

→ Chapter "Specifications" – "InjectionSystem"

Injection S (Symmetrical InjectionSystem)

With the symmetrical InjectionSystem, the flow can be in either direction.

Injection A (Asymmetrical InjectionSystem)

With the asymmetrical InjectionSystem, the flow direction is set in advance. A brief reverse operation is possible.

6.4 Pump connection



ATTENTION

Risk of breakage due to connectors under tension!

Flange connections can exert excessive forces on the machine.

The connectors must be mounted stressless. In other words, the connectors have to be precisely one in front of the other, even when they are not screwed into place.

Note the **tightening sequence** when mounting the connectors:

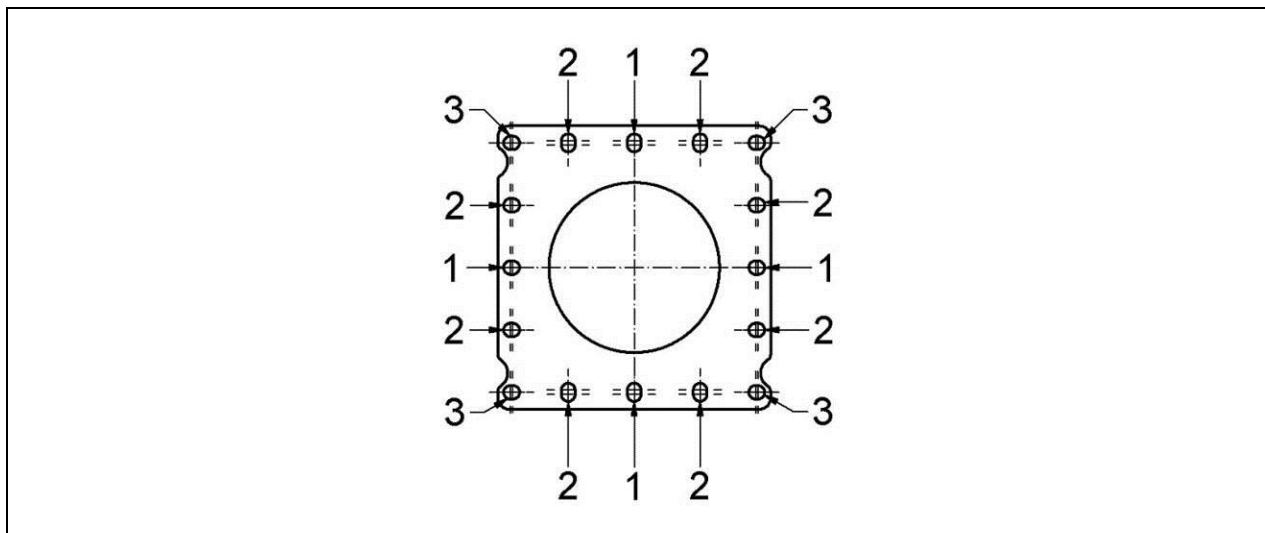

Fig. 9: Tightening sequence

Also observe and do not exceed the specified maximum permissible flange loads and bending moments for the pump connectors: see "Dimension sheet".



Installation of studs

Before installation, coat the thread of the studs with adhesive (part no. BKL.005).



Tightening torques

M6 stud (A2, stainless steel): 8 Nm

Retighten all bolts for fastening the connections after 20 operating hours and then every 2000 operating hours (at least once a year).



ATTENTION

Before installing stainless steel bolts and stainless steel nuts:

Clean threads and contact surfaces. Apply anti-seize paste (part no. BKL.014/BAS.001) evenly and in sufficient quantity to the screw head face and bearing face and to the thread using a brush or filling knife etc. to avoid seizing of stainless steel.

6.5 Base, support surface for machine

6.5.1 Machine without base



WARNING

Risk of crushing or concussion due to falling machine caused by insufficient stability!

- The machine must be securely fastened to the supporting surface. The machine must never be held in position by the connected pipe as this could result in the couplings breaking or failing.
- Retighten all machine fastening screws and nuts after 20 operating hours and then every 2000 operating hours (at least once a year).

6.5.2 Machine and motor on base C (with coupling)



CAUTION

Impairment of communication and discomfort due to machine vibration!

A tensioned base or insufficient fastening of the machine and motor to the base can lead to machine vibrations and discomfort.

- Install the base in a stressless manner on the support surface.
- Retighten all screws and nuts for fastening the motor and the machine to the base after 20 operating hours and then every 2000 operating hours (at least once a year).

After fastening the machine to the base and the base to the ground on which the machine is standing, the coupling orientation must be checked and realigned, if necessary.

In addition, also read and observe the following:  "Coupling manufacturer's operating instructions"



WARNING

Injuries caused by friction, catching, abrasion from the exposed rotating drive shaft or coupling!

If the machine starts up unexpectedly during adjustment or repair work on the coupling or the dismantled coupling guard, this can result in accidental contact with the exposed rotating drive shaft or coupling.

Before performing adjustments or repair work on the coupling, switch the machine off and secure it against being switched on again.

6.5.3 Coupling orientation



ATTENTION

Vibration and wear due to incorrectly oriented coupling!

If completely assembled at the Vogelsang plant, the alignment between the machine and the motor has been optimally adjusted.

In the case of a drive provided by the operator, the tolerance specifications of the manufacturer of the coupling must be complied with.

- To protect the machine against damage caused by vibrations, check the orientation of the coupling before start-up and then every 2000 operating hours (at least once a year) and correct it, as necessary → Fig. "Orientation procedure".
- If alignment errors are determined or after any blockage e.g. by foreign matter, check the function of all parts of the drive line and readjust it, if necessary.
- In the event of any unusual running noises or vibrations, check the coupling immediately, regardless of the maintenance intervals.

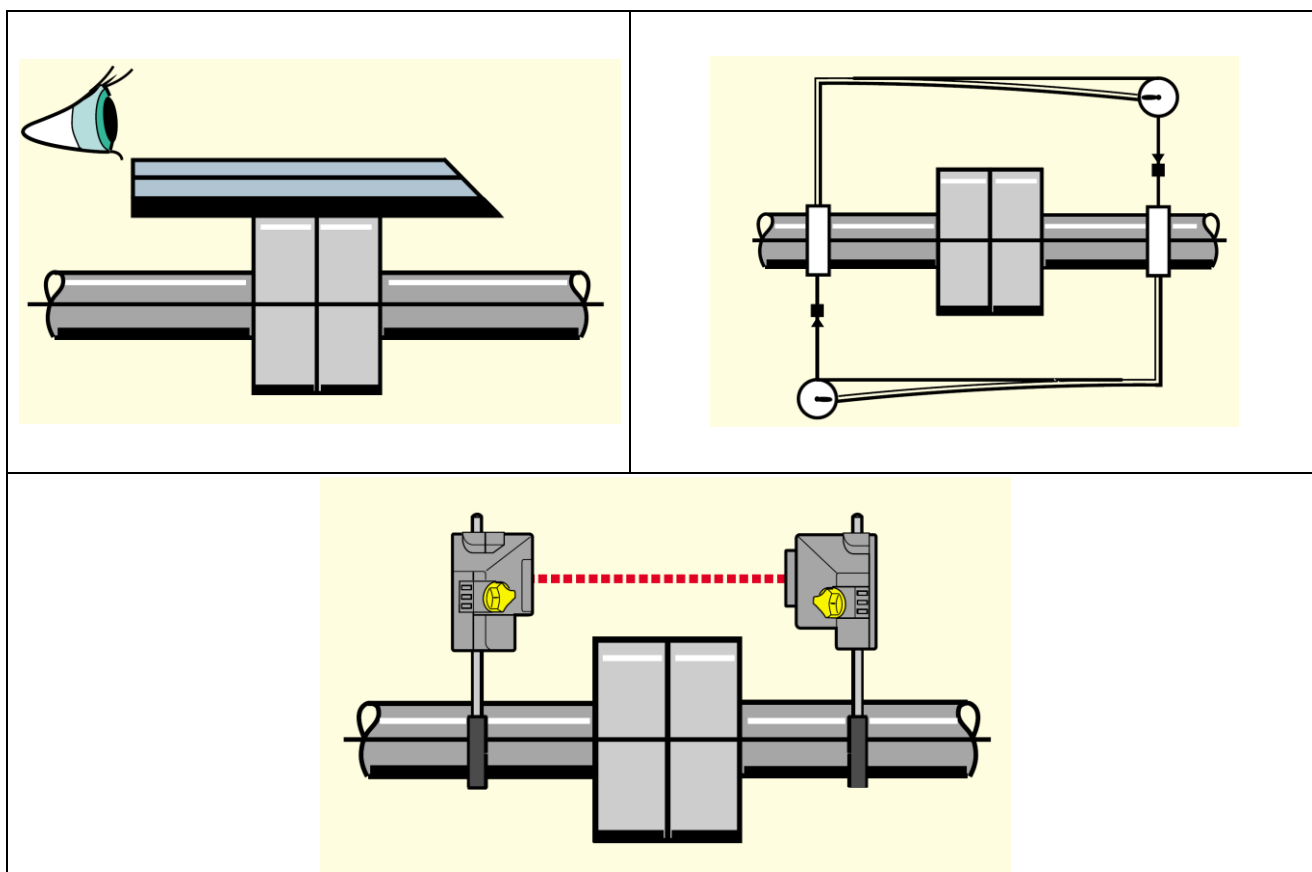

Fig. 10: Orientation procedure

6.5.4 Coupling guard



WARNING

Injuries caused by friction, catching, abrasion from the exposed rotating coupling!

During start-up and operation of the machine, the rotating coupling may be touched accidentally.

The coupling must be completely covered by a coupling guard.

- The machine may only be started up again after maintenance, repairs or troubleshooting once all the protective equipment has been re-installed.
- Check the fixed screw connection of the coupling guard after the first 20 operating hours and then every 2000 operating hours (at least once a year).

6.5.5 Machine and motor on base B (belt drive)



For this type of construction, please request the document “Technical information TINF.PU.020.xx, accompanying sheet for belt drives”.

For machines with belt drive check the belt tension acc. to the accompanying sheet → **Chap.** “Maintenance plan”:

- At start-up
- Before and after long periods of shutdown
- After the first 10 operating hours
- Every 2000 operating hours, once per year minimum

6.5.6 Machine on hand cart



WARNING

Risk of crushing or concussion due to falling machine caused by insufficient stability!

Secure the hand cart against toppling or rolling during standstill and when the pump is in operation.

6.5.7 Machine on three-point base



WARNING

Risk of crushing or concussion due to falling machine caused by insufficient stability!

Before operating the pump, ensure that the three-point base is properly attached and secured to the tractor.

6.6 Drive

The technical specifications for the drive system to be installed are determined by the machine's specifications → **Chap. "Specifications"**.

In addition, also read and observe the following:



"Technical information for the drive system to be installed"



"System requirements - Electrical drive technology"



WARNING

Injuries caused by friction, catching, grazing from the exposed rotating drive shaft/coupling!

If the machine starts up unexpectedly during assembly or repair work, this can result in accidental contact with the exposed rotating drive shaft/coupling.

- The coupling area must be protected by a screwed cover.
- The machine may only be started up again after maintenance, repairs or trouble-shooting once all the protective equipment has been re-installed.
- Before starting assembly and repair work on the coupling, switch the machine off and secure it against being switched on again.

6.6.1 Electric drive

Connection to the energy supply may only be established by qualified technical personnel **following** installation in the pipe.



RISK OF ELECTRIC SHOCK

Touching live parts leads to dangerous electrocution.

This can result in electric shock, burns or death.



RISK OF ELECTRIC SHOCK

The equipotential bonding shall be executed in accordance with standard EN 60204-1. In other words, all metallic parts of the machine or plant must be connected electroconductively to each other or to the signal ground.

In addition, also read and note the following:  "Technical information for geared motor"

Before connecting the geared motor (electric motor with or without gearbox)

- Check that the power supply is correct for the motor.
- Check that the power feed and fuse protection are adequately dimensioned to allow for multiple rotation direction changes and peak loads within a short period of time.
- Be sure to follow the cable layout diagram on the inside of the motor terminal box cover.
- Note that the PTC resistor of the geared motor must be connected to the terminals provided on the pump control, to a PTC control unit or to a variable frequency drive with a PTC input (each available as an option).
- Install a maintenance switch in close proximity to the machine (recommendation).

Before start-up or long-term storage

The seal on the vent screw (if present) must be removed in order to prevent overpressure build-up in the gearbox and thus leakage.

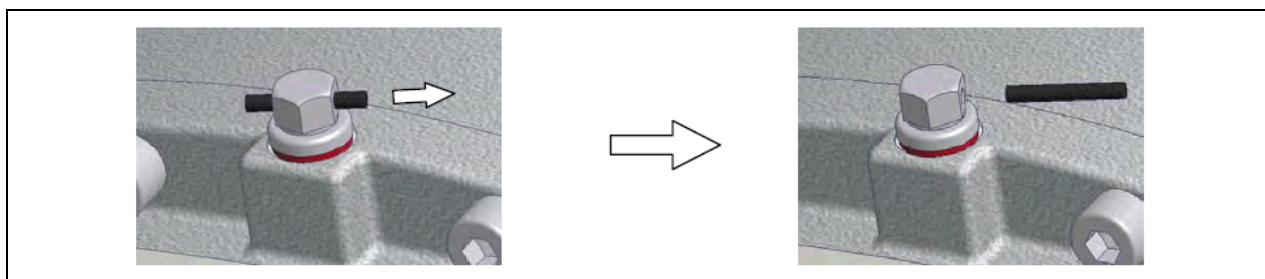

Fig. 11: Vent screw on the gearbox (removing the seal)

6.6.2 Hydraulic drive

Connection to the energy supply may only be established by qualified technical personnel **following** installation in the pipe.



WARNING

Risk of infection from hydraulic oil!

Leakages can occur due to seal faults.



- Personnel must wear suitable protective clothing.
- The connection to the power supply must be established by qualified technical personnel.

In the event of injuries with hydraulic oil, consult a doctor immediately!

In addition, also read and observe the following:  "Technical information for hydraulic motor"

Hydraulic hose lines

- Before connecting hydraulic hoses, read and follow the manufacturer's specifications for hydraulic motors.
- Observe the permissible hydraulic pressure and the permissible delivery rate.
- Connect the overflow oil line in accordance with the manufacturer's instructions.
- Replace hydraulic hose lines that show signs of damage or ageing. Only use genuine Vogelsang hydraulic hose lines.
- The date of manufacture of the hydraulic hose line is displayed on the pressing component of the connector. The period of usage for the hydraulic hose line should not exceed 6 years (although 5 years is recommended), including a possible storage period of no more than 2 years.

Installing two hydraulic motors

When two hydraulic motors are installed, they are operated parallel and the torques of both motors are added.

Control unit

In the event of high hydraulic motor speeds, never suddenly set the control unit to "lock position" in order to avoid pressure peaks. Whenever possible, switch from "operation" to "floating position".

6.6.3 Combustion engine drive

In addition, also read and note the following:  "Technical information for combustion engine"

Before start-up

- Fill the tank with fuel. The fuel must meet the specifications in the operating instructions.
- Fill up with sufficient operating oils. The oil grade must meet the specifications in the operating instructions.



DANGER

In enclosed or poorly ventilated spaces, poisonous engine exhaust gases can lead to a loss of consciousness and death!

- Never operate the engine in enclosed or poorly ventilated spaces.
- Do not breathe in exhaust gases.



DANGER

Fire hazard due to fuel!

Leaking or spilled fuel can ignite on hot motor parts and cause serious burns.

- Only refuel when the engine is switched off.
- Never refuel in the vicinity of open flames or ignitable sparks.
- Do not smoke.
- Do not spill fuel.



WARNING

Risk of burning due to exposed hot surfaces!

Parts of the exhaust system and the surface of the engine become hot during operation and must not be touched until they cool down again once the engine has been switched off.

6.7 System control



Controls

We recommend our control system, which is specially designed for use with the pump in order to provide optimum service life for the pump. All connections necessary for connecting the pump to a control system are available.

If a new control is made by a switching system manufacturer, the new manufacturer must make the network connections in AC4.

Please contact us with regards to the correct programming of the control system  .



Automatic mode requires monitoring equipment

Machines that are operated in automatic mode must be equipped with a temperature and pressure monitoring system. This monitoring equipment can be obtained from us as an option.

Variable frequency drive operation

In general, rotary lobe pumps can be used in variable frequency drive operation.

Advantages:

- Adaptation to operating conditions (viscosity, delivery rate, $NPSH_{avail.}$)
- Wear compensation
- Speed-proportional delivery rate (see characteristic line)
- Increasing acceleration and deceleration times
 - Reduces pressure peaks
 - Reduces the risk of pipe vibrations

A variable frequency drive with a linear torque characteristic line is to be used. The starting torque / nominal torque ratio must be > 1.3 .

7 Start-up



Personnel for start-up and operation

We recommend starting up the machine in the presence of persons who are responsible for further operation of the machine.



WARNING

Risk of injury, catching by rotating rotary lobes!

The pump may only start-up if the inlet and outlet pipes are connected so that access to the rotating rotary lobes in the pumping chamber is not possible.

Checklist before start-up

Pump connection

- Are the inlet and outlet lines connected?
- Are the drain cocks closed, and is the pump filled with fluid?

Base, coupling

- Is the coupling, if present, correctly aligned (see documents provided by the coupling manufacturer)?

Drive

- If a PTO drive is present, are the cardan shafts correctly aligned?
- Is the belt tension, if applicable, OK?

See  "Technical Information TINF.PU.020.xx, accompanying sheet for belt drives".

- Is the motor connected correctly to the power supply, if applicable, (→ documents provided by the motor manufacturer)?
 - Star or delta connection, voltage, frequency (see name plate and inside of terminal box)?
 - Motor protection ensured, e.g. by a circuit breaker?
 - A short switching time should be set for star-delta starting (if present).
 - A short start ramp should be set for the soft starter, if present.
 - Is the variable frequency drive/soft starter, if present, designed and configured correctly?
 - Units should be suitable for heavy starting
- Is the motor connected correctly to the hydraulic lines, if applicable, (→ documents provided by the motor manufacturer)?

Buffer chamber, pump gearbox

- Are the optional buffer chamber assemblies correctly installed? Are they correctly adjusted? Is the buffer chamber pressure OK (if applicable)? → **Chapter "Maintenance" – "Buffer chamber"**
 - Is the type of buffer or quenching fluid OK?*
 - Is the fluid level in the buffer chamber OK?*
 - Are the oil grade and oil level in the gearbox of the pump OK?*
- *Requirements met by the pump when delivered*

Flow direction, pipe system

- Is the flow direction OK? Check the pump's direction of rotation.
- Is the pipe system sealed and free of leakage?
- Is unobstructed flow guaranteed in the pipe system?
Positive displacement pumps must never be operated in a sealed pipe.

Sensors, safety

- Have all safety devices been installed and is their proper functioning ensured?
- Are safety devices or maintenance switches easy to reach?

Put the pump into operation and check inlet and outlet pressure, speed and capacity.

8 Maintenance



WARNING

Risk of injury (catching, crushing, collision) due to rotating rotary lobes if the machine starts up unexpectedly!

Before starting maintenance and repair work (opening covers, disassembling connectors) and before troubleshooting, switch the machine off and secure it against being switched on again.



WARNING

Risk of injury from working materials escaping under high pressure!

When the drain plugs on the gearbox and buffer chamber are loosened or the buffer fluid tank cover is opened, working materials can spray out under high pressure.



- Personnel must wear suitable protective clothing.

Before carrying out maintenance and repair work, release the buffer chamber pressure.

- To protect against fluids spraying out, carefully and slowly open the buffer chamber and the gearbox. Cover the valves or screws to be removed with a cloth or similar item where appropriate.

8.1 Buffer chamber

In the following chapters, we describe the following possible **buffer chamber assemblies**:

- 1 → Chapter "Pressurisable buffer fluid tank"
- 2 → Chapter "Depressurised quenching fluid tank"
- 3 → Chapter "Pressure valve"
- 4 → Chapter "Plugs"

Buffer chamber assemblies act to improve control of the pump shaft seal. The fluid level and the set pressure can be monitored, depending on the design.

Electronic buffer chamber monitoring is also possible. Ask us for more information. ☎️✉️

If your pump is equipped with a dry buffer chamber or a circulation system, please read the corresponding → **Chapter** ""Dry buffer chamber" sealing system" or "Circulation system on the cartridge mechanical seal".

8.1.1 Pressurisable buffer fluid tank

The pressurisable buffer fluid tank (hereafter referred to as "tank") with manual air pump ensures a constant and defined buffer chamber pressure (buffer chamber pressure = tank pressure). The tank provides reliable monitoring of the buffer chamber.

Installing the tank (before pump start-up)

1. Remove the plug from the buffer chamber.
2. Open the tank: undo the upper coupling of the upper housing (hold the union nut firmly in place so that the lower coupling is not detached).
3. Screw the tank directly into the cast body of the buffer chamber. Fill the tank about one quarter full (when delivered, the buffer chamber is already filled).
4. Close the tank and use a manual air pump or a compressed-air supply outlet to set the required tank pressure.

Topping up buffer fluid (maintenance and inspection)

→ Fig. "Buffer fluid tank" and "Filling/draining the buffer chamber"

1. Release the pressure in the buffer chamber via the valve on the tank.
2. Open the tank: undo the upper coupling of the upper housing (hold the union nut firmly in place so that the lower coupling is not detached).
3. Top up the buffer fluid in the tank. The tank must be one quarter full.
4. Close the tank and use a manual air pump or a compressed-air supply outlet to set the required tank pressure.

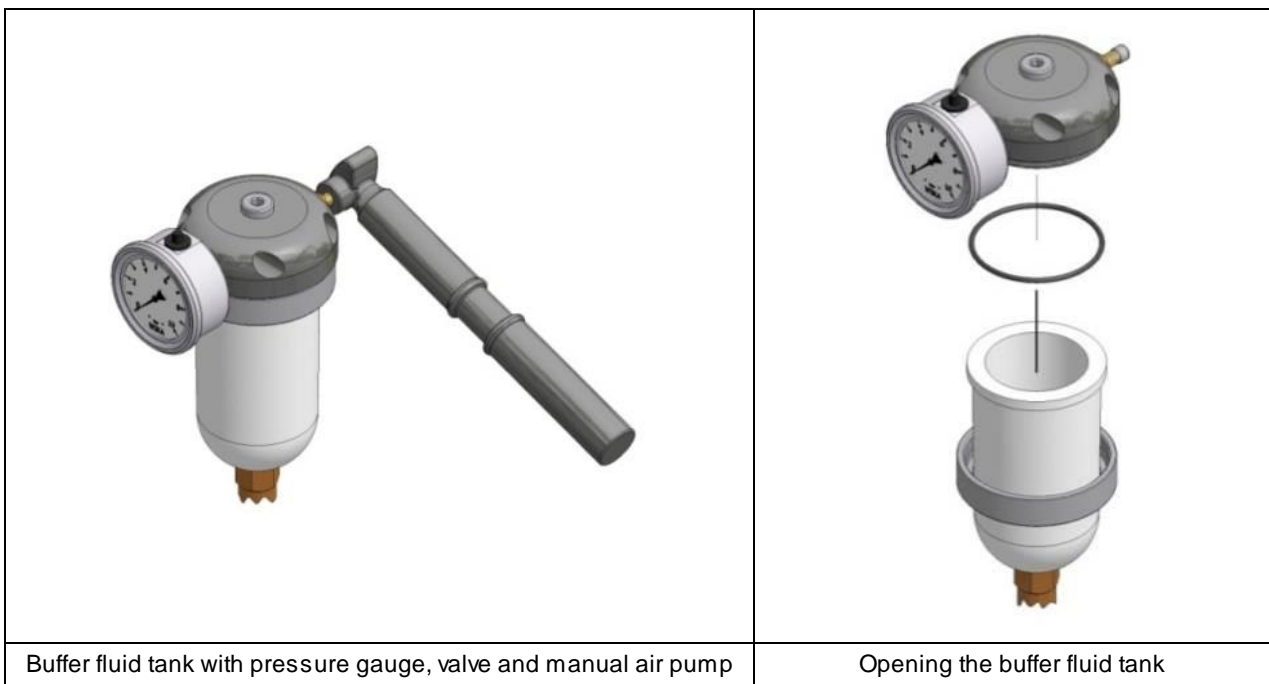

Fig. 12: Buffer fluid tank

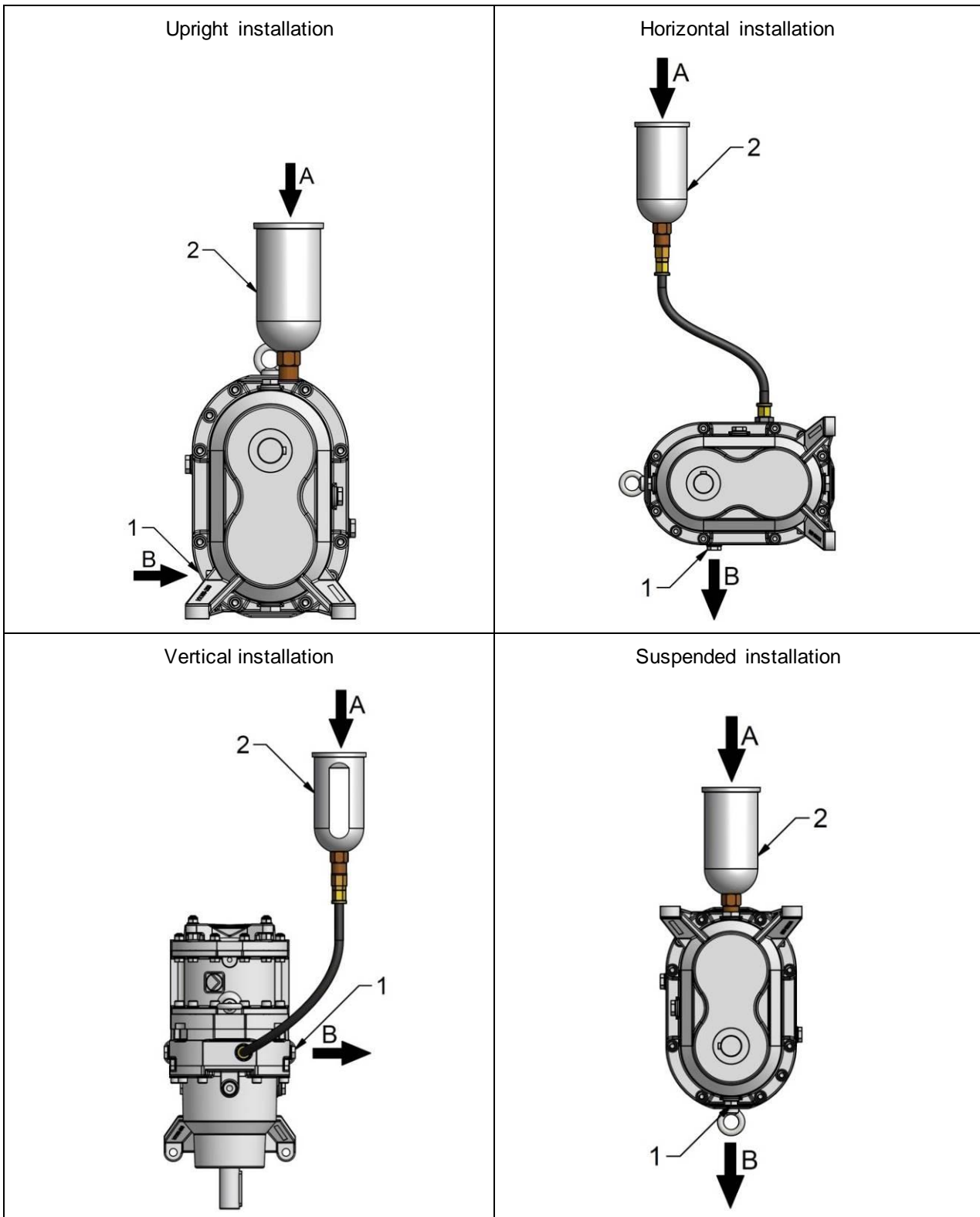

Fig. 13: Filling/draining the buffer chamber

- 1 | Screw plug
- 2 | Buffer fluid tank

- A | Filling
- B | Draining

Tank pressure

The tank pressure should be about 0.5 bar higher than the average pressure in the pump.

Tank pressure = 0.5 bar + (pressure on the suction side + pressure on the discharge side) / 2

Example

A pump primes with 0.4 bar suction and discharges with 2.0 bar overpressure.

Pressure on the suction side: -0.4 bar, pressure on the discharge side: 2.0 bar.

$$\text{Tank pressure} = 0.5 \text{ bar} + \frac{(-0,4\text{bar} + 2\text{bar})}{2} = 1.3 \text{ bar}$$

In this example, the tank pressure is 1.3 bar.

Regardless of this, the tank pressure should not exceed 5 bar with a single mechanical seal and should not exceed 10 bar with a double mechanical seal.

**Rotary lobe change and Cartridge mechanical seal change**

Before a rotary lobe and Cartridge mechanical seal change, reduce the **tank pressure** and increase it again after changing.

Trouble indication

Possible indications of trouble in the sealing system after the running-in period:

- Severe contamination of the buffer fluid in the tank
- Buffer fluid escaping (tank is empty)
- Increase in buffer fluid level (tank is full)

**Buffer fluid characteristics**

- The hydrodynamic lubrication film of a mechanical seal can cause:
 - Slight contamination of the buffer fluid
 - A slight increase or reduction in the buffer fluid level
- A slight increase in the buffer fluid level is also possible due to thermal expansion during pump operation.

8.1.2 Depressurised quenching fluid tank

The quenching fluid is used for non-pressurised lubrication and cooling of the pump shaft seal. Any leakage of fluids (pump medium or gear oil) is absorbed by the quenching fluid.

The installation of the quenching fluid tank and the topping up of quenching fluid is as described in → **Chapter** "Pressurisable buffer fluid tank".

The instructions for pressurising the tank do not apply in the case of buffer chamber assembly "depressurised quenching fluid tank".

Please also observe the "Trouble indication" and "Buffer fluid properties" in → **Chapter** "Pressurisable buffer fluid tank".

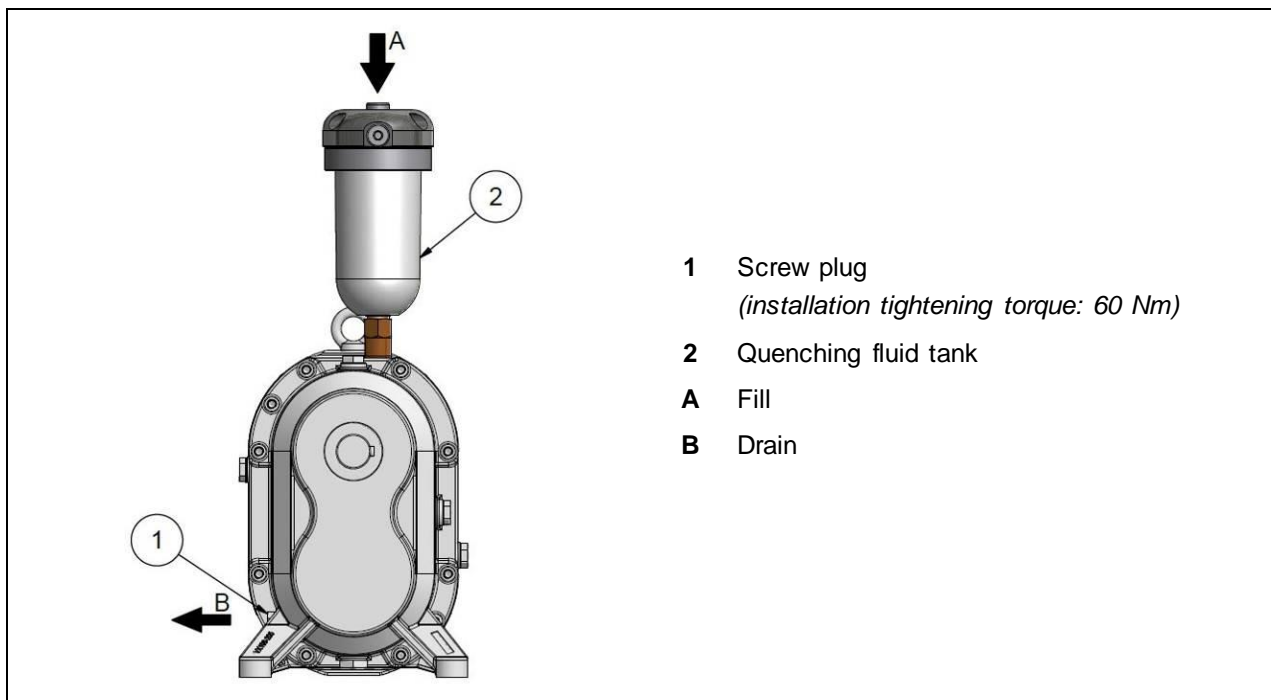

Fig. 14: Pump with quenching fluid tank

8.1.3 Pressure valve

The pressure valve ensures a slight pressurisation of the buffer fluid. If the pressure rises too much (>1.5 bar) or there is a leak on the pump shaft seal, the leaking fluid (pump medium or gear oil) can escape via the valve. A collecting tank can be connected if necessary.

Recommendation: to be able to monitor the buffer chamber pressure and the buffer fluid level, a buffer fluid tank should be installed instead of the pressure valve.

→ Fig. "Pump with pressure valve"

Dismount the pressure valve for inspection of buffer fluid in the buffer chamber and for topping up buffer fluid.



Air buffer

When adding buffer fluid, leave a buffer of air above it (about 1 cm distance between the oil level and the bearing seal housing) → Fig. "Pump with pressure valve". The air buffer prevents the buffer chamber fluid from escaping through the pressure valve due to thermal expansion.

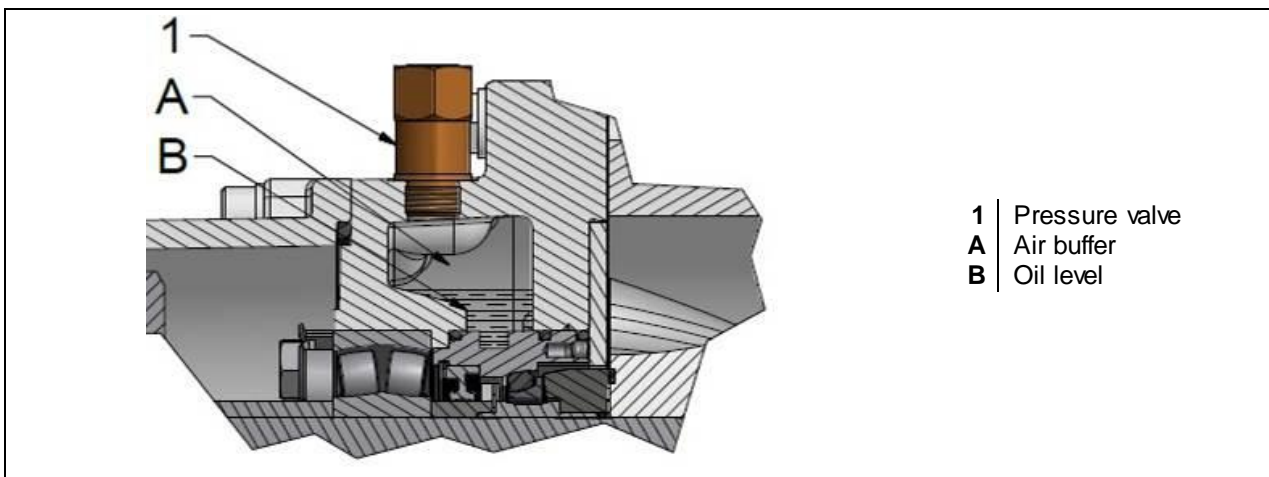

Fig. 15: Pump with pressure valve

8.1.4 Plugs

The buffer chamber assembly with plugs is used only for special designs, for example submersible pumps.

→ Fig. "Pump with pressure valve"

To add small quantities to the buffer chamber, dismount the upper plug (instead of pressure valve).



Air buffer

When adding buffer fluid, leave a buffer of air above it (about 1 cm distance between the oil level and the bearing seal housing), see C → Fig. "Pump with pressure valve". The air buffer prevents the buffer chamber fluid from building up an unacceptably high pressure due to thermal expansion.

8.1.5 Buffer or quenching fluid - type

For optimum functioning of the mechanical seal, we recommend the oil grades listed in → **Chapter "Oils"**. Please check your order confirmation to see whether the buffer chamber of your machine is filled with an oil that deviates from this chapter.

Only use the oil specified on your order confirmation.



ATTENTION

To prevent premature wear of the seal, mineral oils or greases must not be used with EPDM O-rings. Use glycol as an alternative.

To prevent contamination of the pump medium, **no fluid** must be filled into the buffer chamber of pumps with the "dry buffer chamber" sealing system.



8.1.6 Buffer or quenching fluid - quantity

0.45 litres (guideline, depending on the buffer chamber assembly → **Chapter "Buffer chamber"**)

8.1.7 Buffer or quenching fluid - inspection and change

Buffer fluid or quenching fluid

- Check:
 - After the first 20 operating hours
 - Every 200 operating hours

Electronic buffer chamber monitoring is possible. Ask us  .
- replace:
 - Every 2000 operating hours
 - When there is severe contamination

When there is intense leakage, replace the cartridge mechanical seal → **Chapter "Changing cartridge mechanical seal"**

→ **Chapter "Maintenance plan"**



Buffer or quenching fluid properties

- The hydrodynamic lubrication film of a mechanical seal can cause:
 - Slight contamination of the buffer or quenching fluid
 - Slight increase or decrease in the buffer or quenching fluid level
- A slight increase in the buffer or quenching fluid level is also possible due to thermal expansion during pump operation.



Environmentally friendly disposal

Treat buffer fluid or quenching fluid, for example, oils and hydraulic fluids, like hazardous waste and dispose of them properly.

8.2 Draining and cleaning the buffer chamber



Draining and cleaning the buffer chamber

- If the cartridge mechanical seal is defective, drain and clean the buffer chamber.
- Before changing a cartridge mechanical seal, drain the buffer chamber and clean it if it is contaminated severely.

Procedure

→ Chap. "Buffer chamber"

1. In case of buffer chamber assemblies with a pressurisable buffer fluid tank or pressure valve, depressurise the buffer chamber before draining or cleaning.
2. Remove the buffer chamber assemblies.
3. Undo the lower screw plug (1) → **Fig.** "Filling/draining the buffer chamber" or → **Fig.** "Pump with quenching fluid tank" and drain the buffer or quenching fluid from the buffer chamber.
4. If there is severe contamination, clean the buffer chamber.
5. Screw the lower screw plug back in (tightening torque: 60 Nm) and install the various buffer chamber assemblies in reverse sequence.
If the lower screw plug is not accessible due to the installation position, a drain pipe can be installed at the side on request. ☎️✉️

8.3 "Dry buffer chamber" sealing system

This sealing system is only used if it is essential to prevent buffer chamber fluid from getting into the pump medium. It is used for pumps that pump pure, non-abrasive media, e.g. water.

To prevent contamination of the pump medium, **no fluid** must be filled into the buffer chamber of pumps with the "dry buffer chamber" sealing system.

Medical white oil, part no. BSS.010, can be used as the gear oil.



Notice

White oil, part no. BSS.010: approved only for continuous operation up to 50% of the max. approved differential pressure of the pump → **Chapter "Specifications"**.

Please contact us. ☎️✉️



ATTENTION

To protect against seal damage, dry running of the pump must be avoided on pumps with a dry buffer chamber. Before start-up, remove the plug from the vent screw (5) → **Fig. "Installation example - dry buffer chamber"** and completely fill the pump chamber with fluid.

Combination of mechanical seal rings in this sealing system

Type of construction: block ring

Mating materials: AISI 304/AISI 316 Ti tungsten carbide coated/carbon

Installation

→ **Fig. "Installation example - dry buffer chamber"**

Connect tank (3) with connecting pipe (4) at the bottom of the buffer chamber. The tank must be installed below the buffer chamber in order to collect medium leakage. The fluid level in the tank should come up no further than the bottom edge of the buffer chamber.

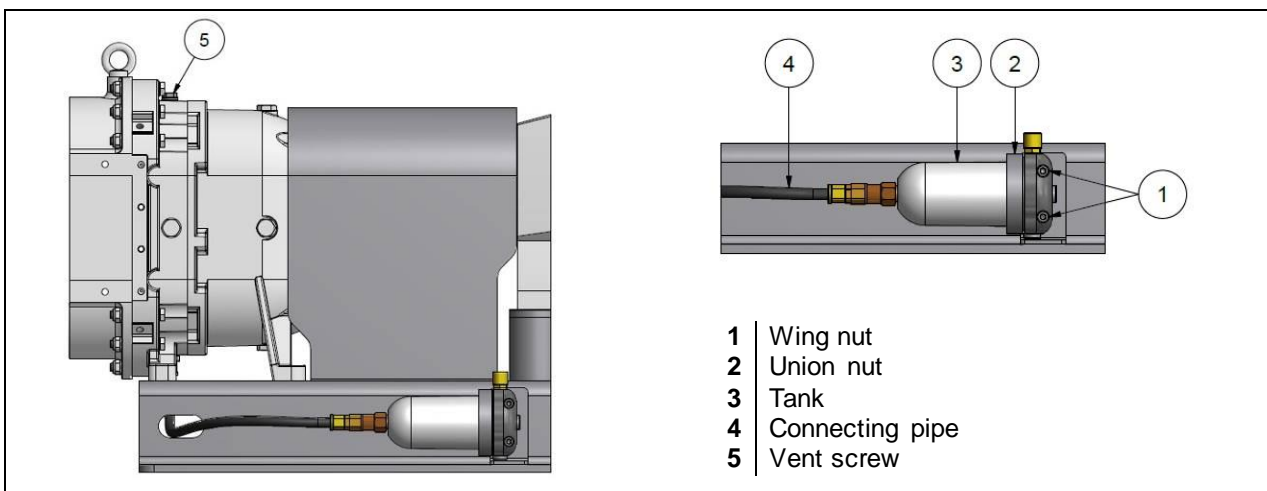

Fig. 16: Installation example - dry buffer chamber

Monitoring the buffer chamber

If the tank (3) is filled with leaked fluid (e.g. pump medium, gear oil or condensed water), undo the wing nuts (1), unscrew the tank cover (union nut (2)) and drain the tank. If the tank is filled by more than half within a month, please contact our service department. ☎️✉️

8.4 Circulation system on the cartridge mechanical seal

The cartridge mechanical seal is flushed by a circulation system. The flushing liquid, e.g. oil, water or glycerine, must be compatible with the pump medium.

Technical prerequisites for the circulation system

- Flushing connectors (1) on the pump → Fig. "Flushing operation".
- Cartridge mechanical seal with the "double mechanical seal" arrangement. The selection of materials for the cartridge mechanical seal depends on the flushing medium.

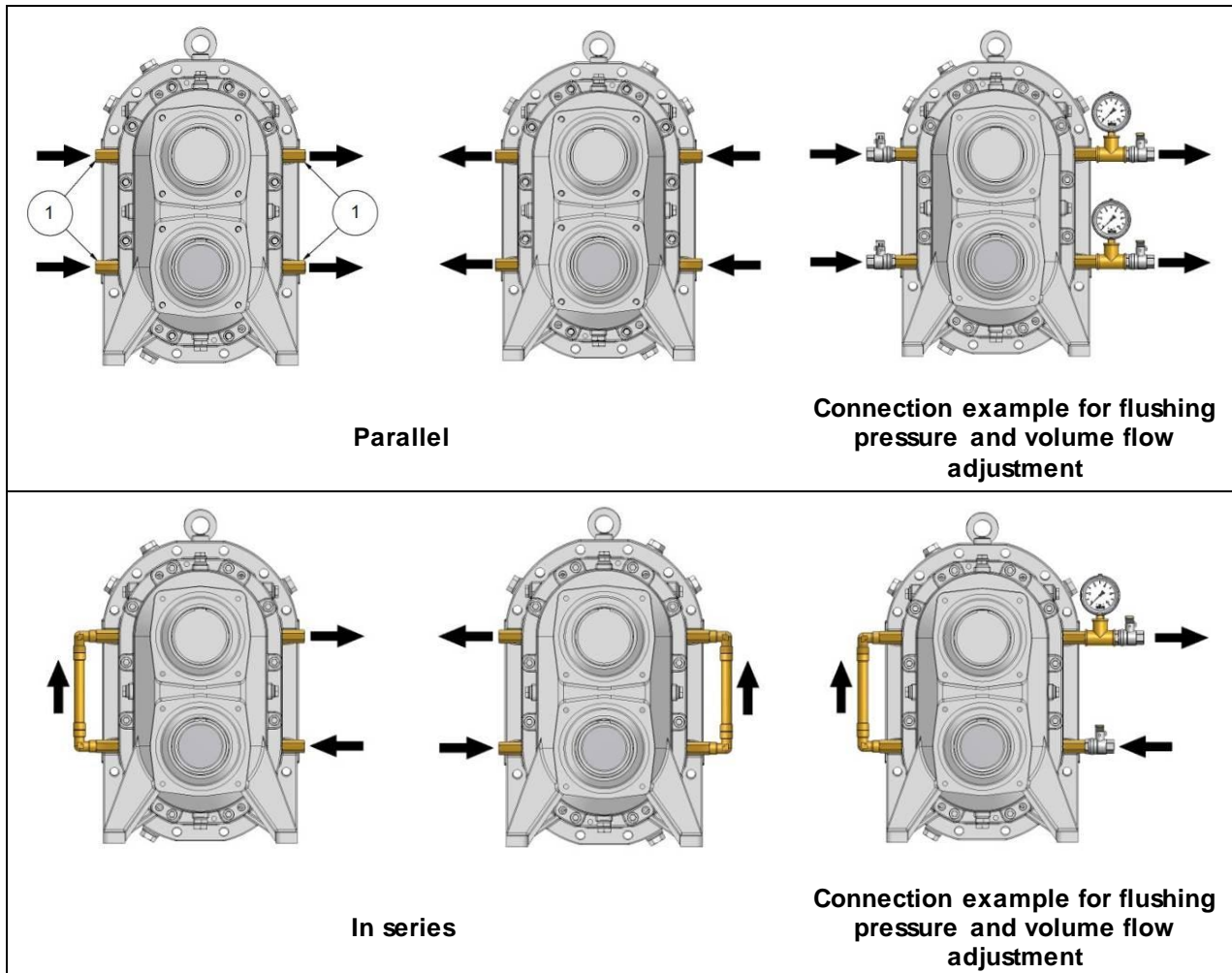

Fig. 17: Flushing operation

Adjustment of flushing pressure and volume flow

→ Fig. "Flushing operation - connection example for flushing pressure and volume flow adjustment".

Adjusting the flushing pressure

The flushing pressure can be adjusted and monitored with a pressure gauge.

The flushing pressure should be about 0.5 bar higher than the average pressure in the pump.

Flushing pressure = 0.5 bar + (pressure on the suction side + pressure on the discharge side) / 2

Example:

A pump primes with 0.4 bar suction and discharges with 2.0 bar overpressure.

Pressure on the suction side: -0.4 bar, pressure on the discharge side: 2.0 bar

$$\text{Flushing pressure} = 0.5 \text{ bar} + \frac{(-0.4 \text{ bar} + 2 \text{ bar})}{2} = 1.3 \text{ bar}$$

In this example, the flushing pressure is 1.3 bar.

If there is an increased risk that medium will get between the sliding surfaces, the pressure should be increased by 1 bar (in the example: 1.3 bar + 1 bar).

Independently of this, the flushing pressure should be no more than 10 bar with a double mechanical seal.

Adjusting the volume flow

The volume flow of the flushing fluid depends on the application and the degree of contamination. The higher the volume flow, the better the flushing effect.

The volume flow should be at least 0.1 l/min and no more than 10 l/min.

We recommend the flushing operation as specified in → Fig. "Flushing operation - parallel":

- Every cartridge mechanical seal is flushed with clean flushing fluid.
- A possible defect of the single cartridge mechanical seal is detected.

Alternatively, the flushing operation can be done as indicated in → Fig. "Flushing operation - in series":

- Flushing fluid is supplied only via the lower flushing inlet and reaches the upper flushing outlet via the two cartridge mechanical seals.

Note with this alternative flushing operation:

- A possible defect cannot be assigned to the single cartridge mechanical seal.
- Possible impurities of the cartridge mechanical seal rinsed for the first time can get into the subsequent mechanical seal.

8.5 Gearbox

8.5.1 Gear oil - grade

We recommend the oils listed in → Chapter "Oils".

8.5.2 Gear oil - quantity

With upright, horizontal and suspended installation of the pump, the gear oil quantity is **0.75 litres**.

With vertical installation of the pump, the gear oil quantity is **1 litre**.

8.5.3 Gear oil – inspection and change

→ Fig. "Gear oil change"

Inspect the gear oil and top up small quantities up to the seal indicator pipe (C) (only top up when the gearbox is at a standstill):

every 500 operating hours, however at least every 3 months

Change gear oil:

- After the first 20 operating hours
- Every 2000 operating hours

The buffer or quenching fluid should be changed at the same time as the gear oil change → Chapter "Buffer chamber assembly".



Environmentally friendly disposal

Treat gearbox oils like hazardous wastes and dispose of properly.

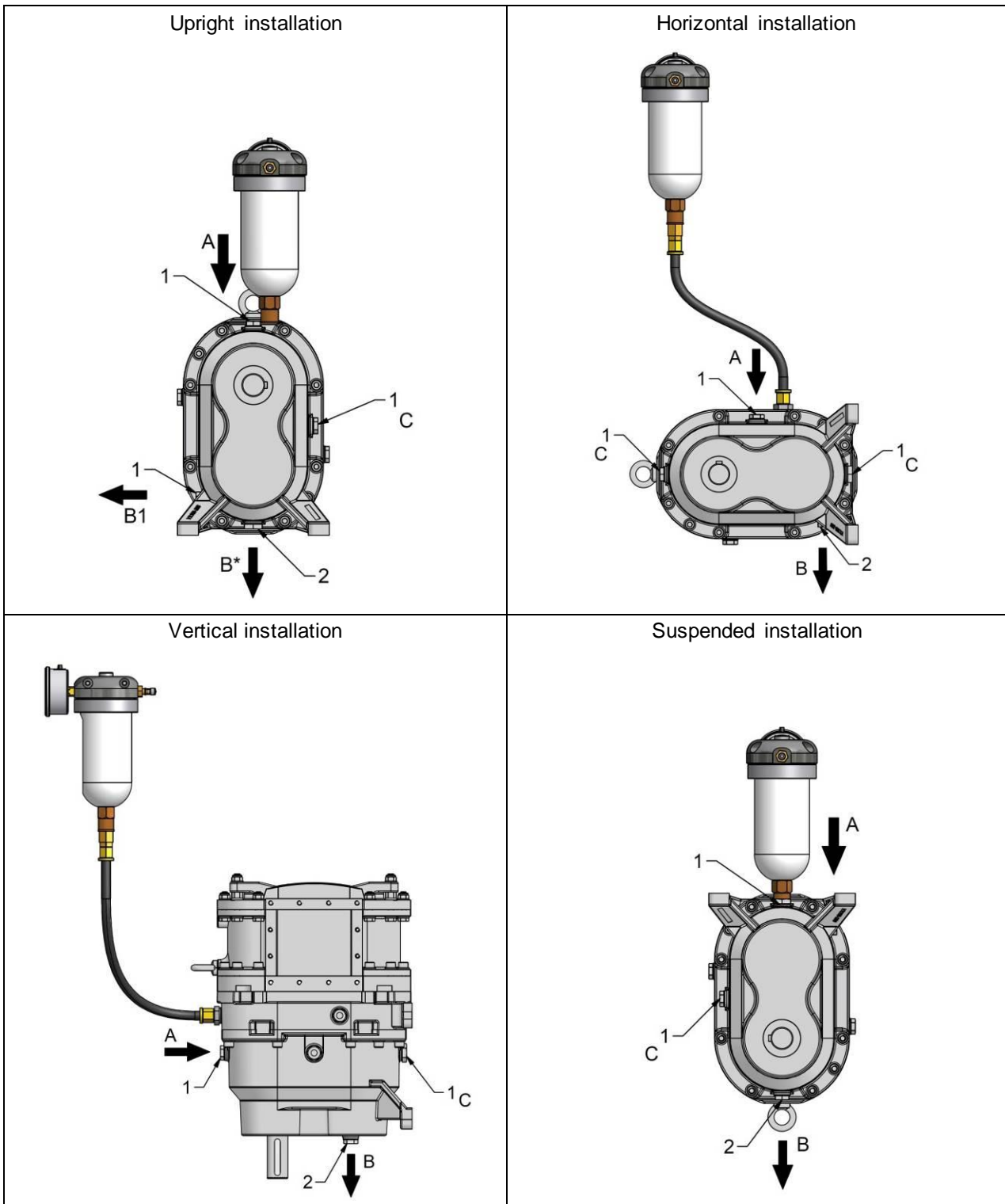

Fig. 18: Gear oil change

- 1 | Screw plug
- 2 | Magnetic screw plug

- A | Filling
- B | Draining
- B* | Alternatively drain via B1
- C | Checking

The screw plug 1 must be at the top, and the magnetic screw plug 2 must be at the bottom.



Tightening torque

Tightening torque for installing the screw plugs → 60 Nm

8.6 Oils

1 Standard Vogelsang oil for pump gearboxes and buffer chamber

| | | |
|------------------------|--------------------------------|------------------------|
| Part number | BSS.006 | |
| Description | EP (Extreme Pressure) gear oil | |
| Trade name (Fuchs) | Titan Gear MP 90 | |
| Characteristics | | Test acc. to |
| SAE class | 90 (85W-90) | DIN 51512 or SAE J306c |
| Kinematic viscosity | | DIN 51562 |
| at 40 °C | 198 mm ² /s | |
| at 100 °C | 17.3 mm ² /s | |
| Flash point | 215 °C | DIN ISO 2592 |
| Pour point | -18 °C | DIN ISO 3016 |
| Damage loading step | ≥ 12 | |
| Water hazard class | Slightly hazardous to waters | |

2 Alternative oils for pump gearboxes and buffer chamber

| | | |
|------------------------|---|---------------------|
| Part number | BSS0021* | |
| Description | Fully synthetic industrial gear oil based on poly-alpha-olefins | |
| Trade name (Fuchs) | Renolin Unisyn CLP | |
| Characteristics | | Test acc. to |
| ISO VG | 220 | DIN 51519 |
| Kinematic viscosity | | DIN EN ISO 3104 |
| at 40 °C | 220 mm ² /s | |
| at 100 °C | 26.7 mm ² /s | |
| Flash point | 260 °C | DIN ISO 2592 |
| Pour point | -42 °C | DIN ISO 3016 |
| Damage loading step | ≥ 12 | |
| Water hazard class | Slightly hazardous to waters | |

* When using BSS0021 oil for the pump gearbox, the maintenance interval for checking and changing the gear oil may be doubled → **Chapter "Maintenance plan"**.

| | | |
|------------------------|--|---------------------|
| Part number | BSS.010** | |
| Description | Medical white oil: water-white, non-fluorescent, tasteless and odourless mixture of hydrocarbons | |
| Trade name (Fuchs) | White oil W 530 (PH.EUR.) | |
| Characteristics | | Test acc. to |
| Kinematic viscosity | | DIN 51562 |
| at 20 °C | 238 mm ² /s | |
| at 40 °C | 68 mm ² /s | |
| at 100 °C | 8.4 mm ² /s | |
| Flash point | 230 °C | DIN ISO 2592 |
| Pour point | -24 °C | DIN ISO 3016 |
| Ambient temperature | -20°C to +40°C | |
| Water hazard class | Slightly hazardous to waters | |

** Approved only for continuous operation up to 50% of the max. approved differential pressure of the pump → **Chapter "Specifications"**. Please contact us. ☎✉



Sealing system with mechanical seal ring made of Duronit

If a mechanical seal ring made of Duronit is used in the sealing system, the damage loading step for the buffer chamber oil must be ≥ 12.

3 Alternative oils for the buffer chamber

| | | |
|------------------------|---|---------------------|
| Part number | BSS.014 | |
| Description | Mineral oil based hydraulic and lubricating oil | |
| Trade name (Fuchs) | Renolin B 15 | |
| Characteristics | | Test acc. to |
| ISO VG | 46 | DIN 51519 |
| Viscosity index | 105 | DIN ISO 2909 |
| Kinematic viscosity | | DIN EN ISO 3104 |
| at 40 °C | 46 mm ² /s | |
| at 100 °C | 6.9 mm ² /s | |
| Flash point | 210 °C | DIN ISO 2592 |
| Pour point | -24 °C | DIN ISO 3016 |
| Damage loading step | ≥ 12 | |
| Water hazard class | Slightly hazardous to waters | |

| | | |
|------------------------|--|---------------------|
| Part number | BSS.016 | |
| Description | Biodegradable, environmentally friendly, multigrade hydraulic oil based on rape seed oil (as per ISO 15308, type HETG) | |
| Trade name (Fuchs) | Hydraulic oil 40 N | |
| Characteristics | | Test acc. to |
| ISO VG | 46 | DIN 51519 |
| Viscosity index | 220 | DIN ISO 2909 |
| Kinematic viscosity | | DIN 51562-1 |
| at 40 °C | 42 mm ² /s | |
| at 100 °C | 9.6 mm ² /s | |
| Flash point | 300 °C | DIN ISO 2592 |
| Pour point | -36 °C | DIN ISO 3016 |
| Water hazard class | Slightly hazardous to waters | |

4 Oils for the buffer chamber with electronic buffer chamber monitoring

| | | |
|------------------------|--|---------------------|
| Part number | BSS.021 | |
| Description | Fully synthetic EP industrial gear oil based on selected polyglycols (PAG) | |
| Trade name (Fuchs) | Renolin PG 100 | |
| Characteristics | | Test acc. to |
| ISO VG | 100 | DIN 51519 |
| Kinematic viscosity | | DIN EN ISO 3104 |
| at 40 °C | 100 mm ² /s | |
| at 100 °C | 19.6 mm ² /s | |
| Flash point | 260 °C | DIN ISO 2592 |
| Pour point | -48 °C | DIN ISO 3016 |
| Damage loading step | ≥ 12 | |

| | | |
|------------------------|--|---------------------|
| Part number | BSS.017 | |
| Description | Fully synthetic EP industrial gear oil based on selected polyglycols (PAG) | |
| Trade name (Fuchs) | Renolin PG 46 | |
| Characteristics | | Test acc. to |
| ISO VG | 46 | DIN 51519 |
| Viscosity index | 203 | DIN ISO 2909 |
| Kinematic viscosity | | DIN 51562 |
| at 40 °C | 46 mm ² /s | |
| Flash point | 240 °C | DIN ISO 2592 |
| Damage loading step | ≥ 12 | |
| Water hazard class | Slightly hazardous to waters | |

9 Repair



WARNING

Risk of injury (catching, crushing, collision) due to rotating rotary lobes if the machine starts up unexpectedly!

Before starting maintenance and repair work (opening covers, disassembling connectors) and before troubleshooting, switch the machine off and secure it against being switched on again.



WARNING

Skin and eye irritation caused by contact with hazardous working materials or media!

All work on the machine can lead to contact with working materials or media.



- Personnel must wear suitable protective clothing.
- The operator must inform his or her staff about any potentially hazardous substances in working materials or media.



ATTENTION

Before installing stainless steel bolts and stainless steel nuts:

Clean threads and contact surfaces. Apply anti-seize paste (part no. BKL.014/BAS.001) evenly and in sufficient quantity to the screw head face and bearing face and to the thread using a brush or filling knife etc. to avoid seizing of stainless steel.



VVA

VVA = All steel and cast parts of the machine coming in contact with the medium are made of stainless steel.

9.1 Conversion and spare parts

Modifications or changes to the machine are only permissible after consultation with Vogelsang. Only accessory parts approved by Vogelsang or genuine spare parts may be used. The use of other parts invalidates the guarantee for any resulting damage.

9.2 Opening the Q cover

1. Depressurise the entire pump unit.
2. Shut off the connected pipes if possible.
3. Drain the pump as much as possible. Attention! Any remaining fluid will flow out of the machine when the Q cover is dismantled.
4. Depressurise the buffer chamber if necessary → **Chapter** "Buffer chamber".
5. Undo hexagon nuts (1) on the Q cover (2).
6. Remove Q cover and remove the O-ring (3).

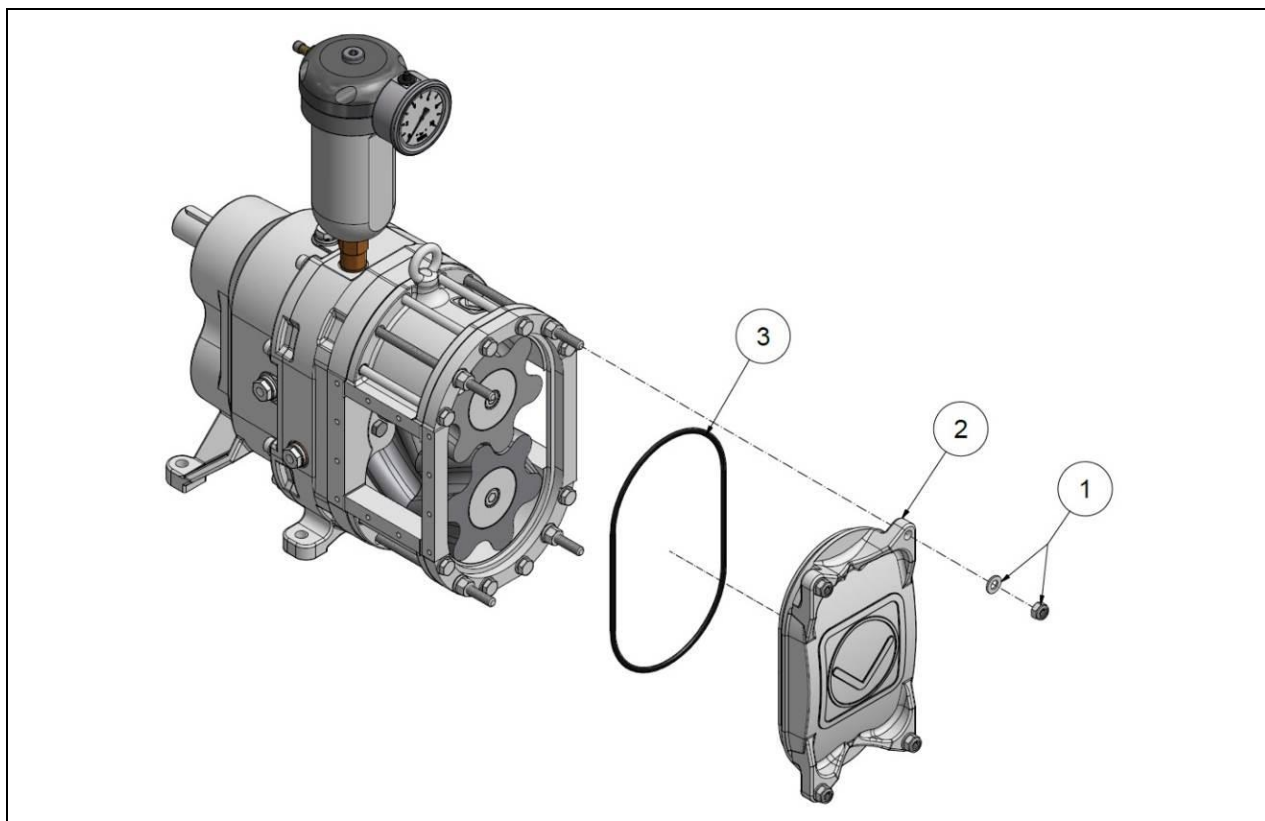

Fig. 19: Opening/closing the Q cover

- | | |
|---|----------------------|
| 1 | Hexagon nut / washer |
| 2 | Q cover |
| 3 | O-ring |

9.3 Rotary lobe change

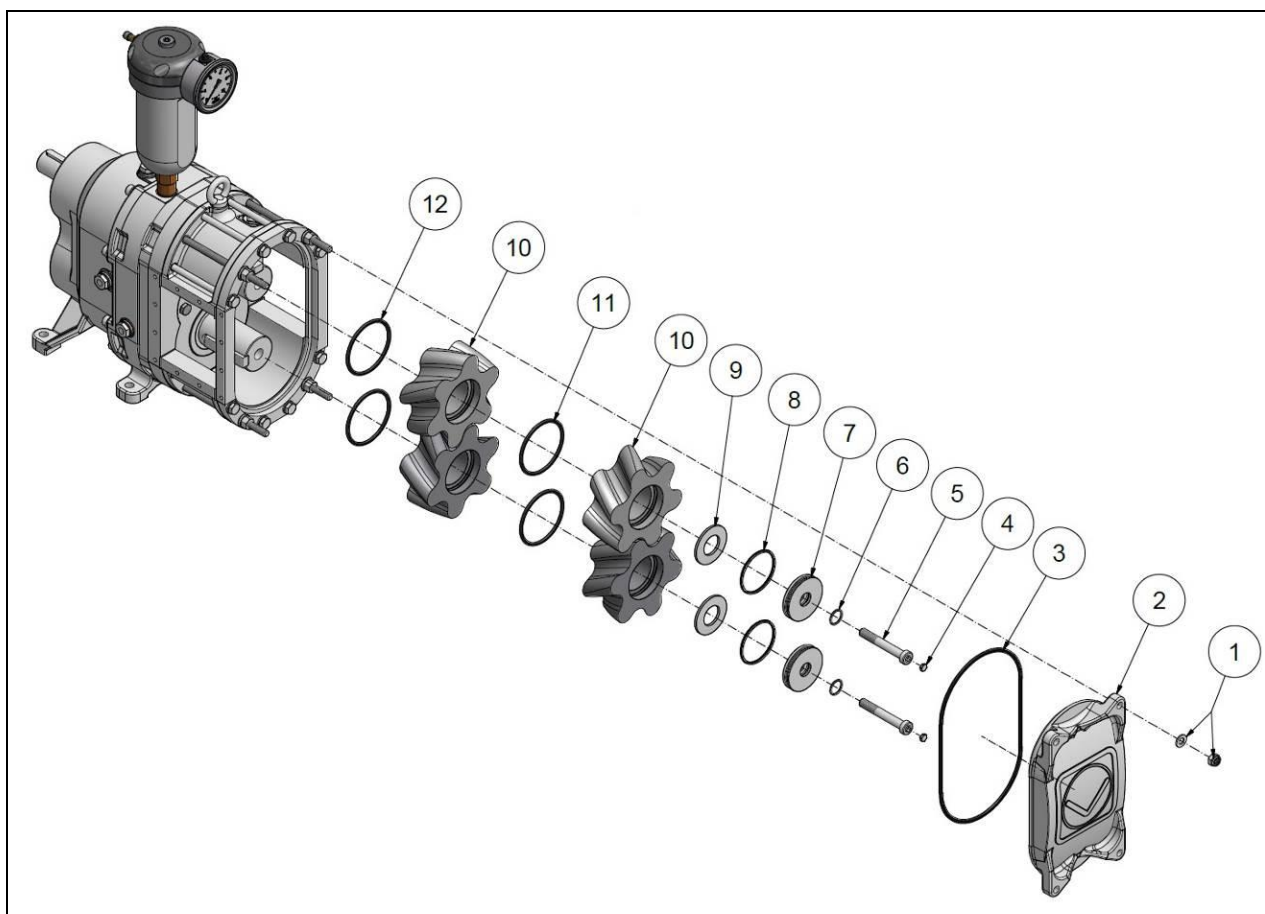

Fig. 20: Rotary lobe change

When assembling, replace the O-rings, cylinder head bolts and plugs.

1. Open the Q cover (2) → **Chap.** "Opening the Q cover".
2. Remove plug (4) and undo the cylinder head bolts (5). Pull off the pressure discs (7) using a suitable bolt (cylinder head bolt) or with the threaded rod of the lobe puller. Remove the O-rings (6, 8).



Notice: VVA series

With the VVA series with rubberised lobes (not with solid material lobes), the lobe core is protected by an additional sealing ring in which the pressure disc and spring washer are located. Dismount this sealing ring and reinstall it after the lobe change.

3. Use a lobe puller to pull the rotary lobes (10) from the upper and lower shafts in pairs → **Chap.** "How the lobe puller works".
4. Before installing the new lobes, thoroughly clean the contact surfaces of lobes and seal components!
5. Install the new rotary lobes in reverse order → **Fig.** "Arrangement of HiFlo and HiFloplus".



Notice: solid material lobes

When assembling solid material lobes, fit an O-ring (12) on the gearbox side of each lobe. When installing two lobe pairs, also fit an O-ring (11) between each lobe pair. The O-rings shown in the figure (12, 11) are not present with rubberised lobes (not solid material lobes).

6. When installing the pressure discs and spring washers, make sure that the spring washers (9) are positioned correctly in the pressure discs → **Fig.** "Position of pressure disc and spring washer". Carefully press the pressure discs and spring washers into the lobe groove. The spring washers must not fall into the extracting groove. Tighten the spring washers and pressure discs with the cylinder head bolt. Attention! Do not use an impact wrench.



Tightening torque of cylinder head bolt

| | |
|--|--------------|
| Cylinder head bolt M 10, 10.9 (steel): | 45 Nm |
| Cylinder head bolt M 10, A4 (stainless steel): | 42 Nm |

7. Install plug (4).
8. Close the Q cover → **Chap.** "Closing the Q cover".
9. Adjust the pressure in the buffer chamber if necessary → **Chap.** "Buffer chamber".



HiFloplus

HiFloplus-rotary lobes, in contrast to HiFlo rotary lobes, have a second groove. The groove, which in the "arrangement HiFloplus" **is not** to be used, is marked in red.

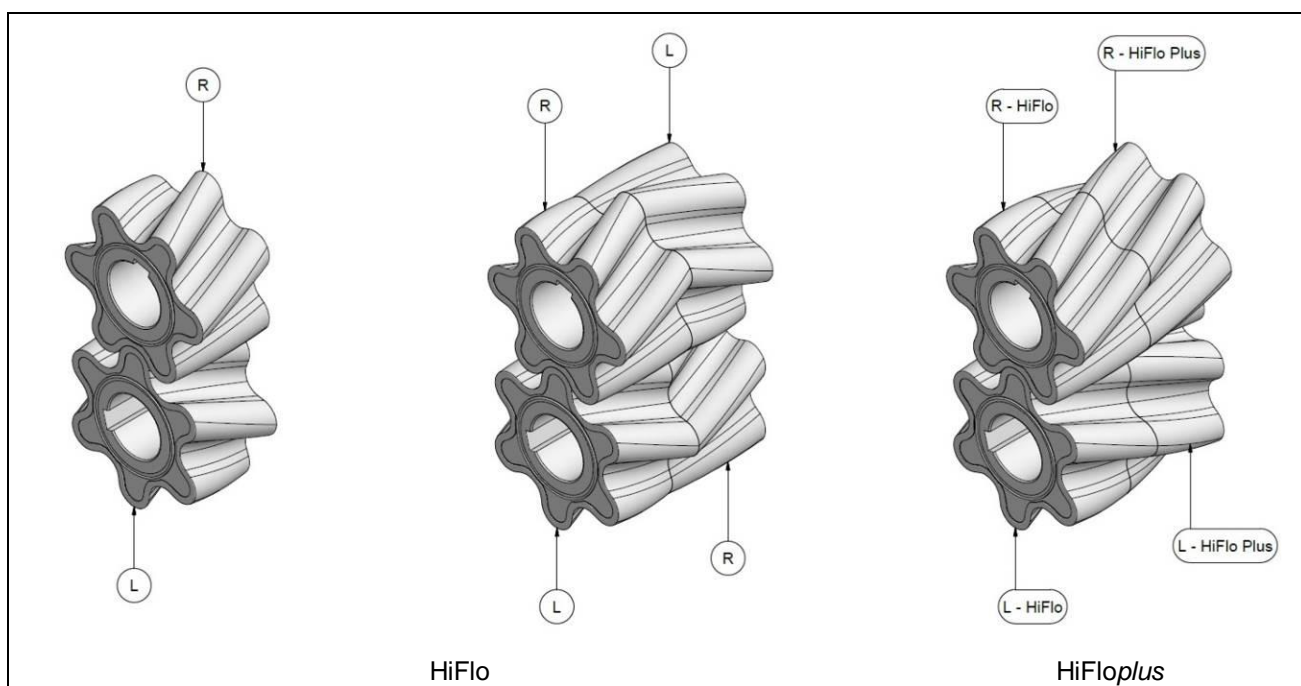

Fig. 21: HiFlo and HiFloplus arrangement
(L = left lobe, R = right lobe)

Position of pressure disc and spring washer

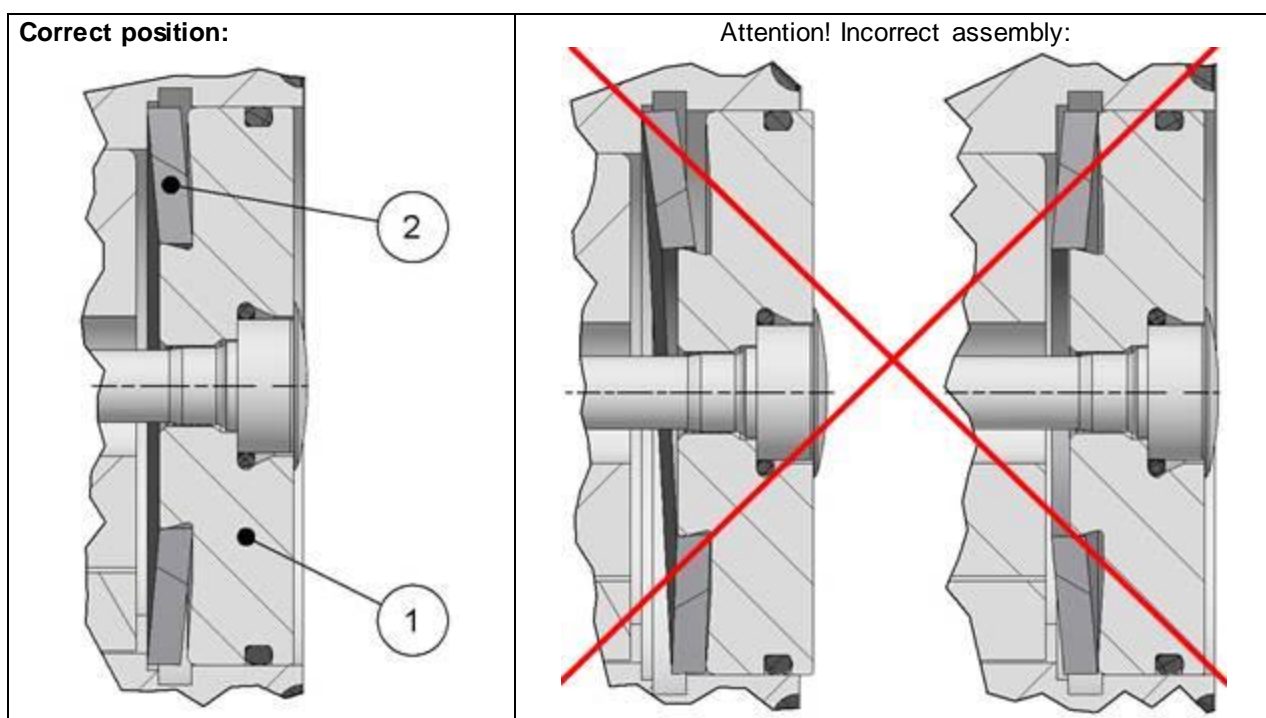

Fig. 1: Position of pressure disc and spring washer

- | | |
|---|---------------|
| 1 | Pressure disc |
| 2 | Spring washer |

9.4 How the lobe puller works



Lobe puller

We recommend using two lobe pullers so the upper and lower lobes can be pulled off as simultaneously as possible.

VX100-45/64Q: Lobe puller part no. PBA.D001.TK.N1

VX100-90/128Q: Lobe puller part no. PBA.D001.TL.N1

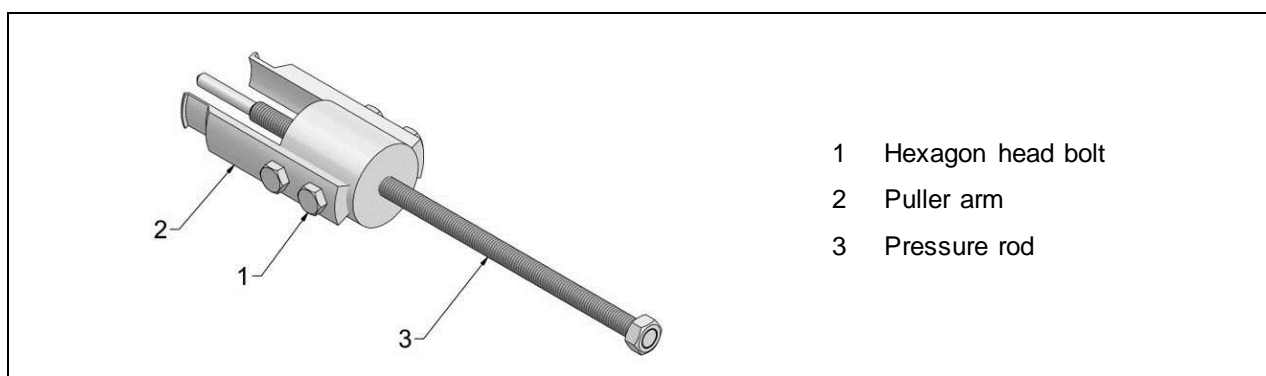

- | | |
|---|-------------------|
| 1 | Hexagon head bolt |
| 2 | Puller arm |
| 3 | Pressure rod |

Fig. 22: Lobe puller components

1. Undo the four hexagon head bolts (1) so that the puller arms (2) can be moved.
2. Hook the two puller arms (2) into the groove provided on the lobe → Fig. "Hooking puller arm into lobe".
3. Tighten the hexagon head bolts (1) with approx. 50 Nm.
4. Tighten the pressure rod (3) to dismount the lobe → Fig. "Pulling out the lobes with lobe puller".

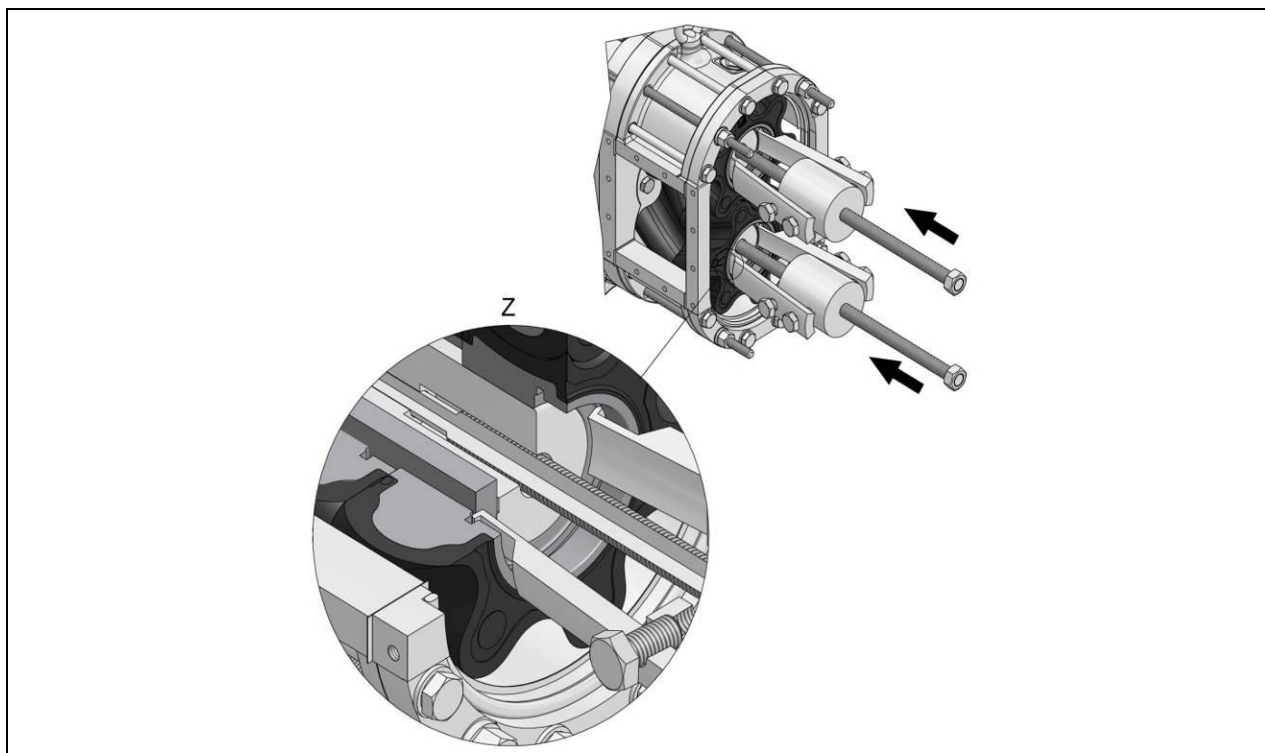

Fig. 23: Hooking puller arm into lobe

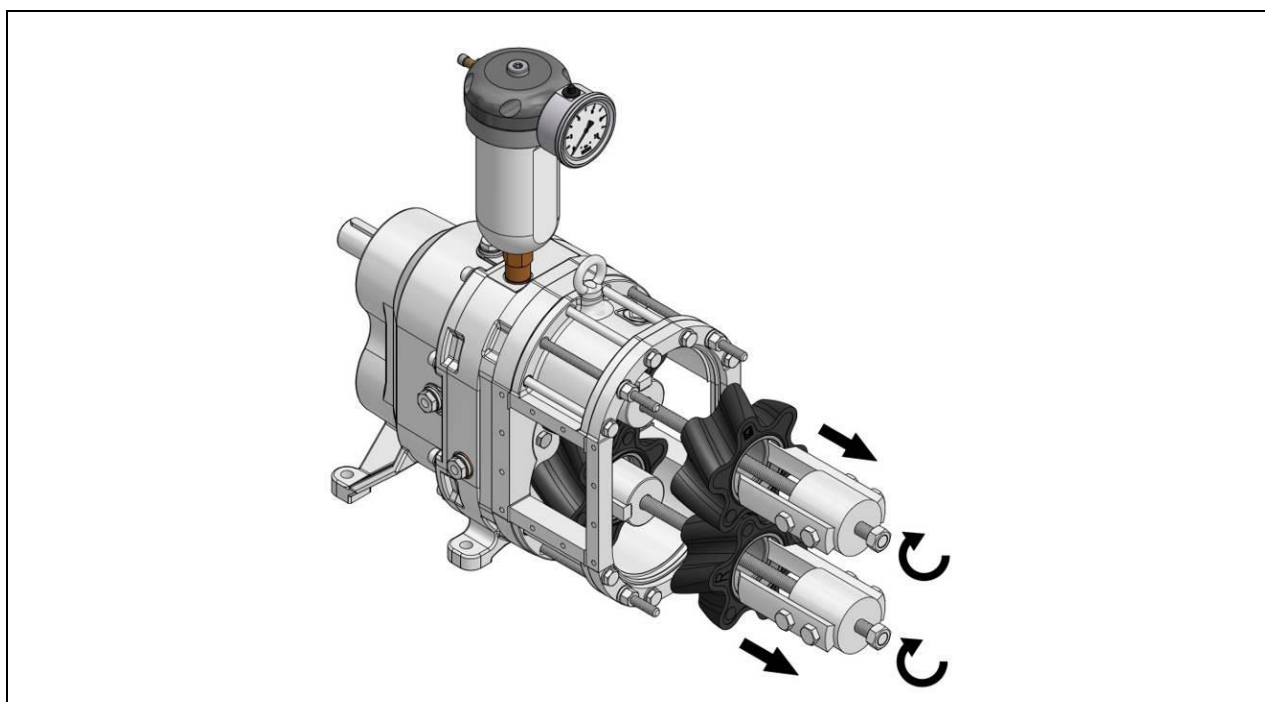

Fig. 24 Pulling out the lobes with lobe puller



Maintenance instructions for lobe puller

- Regularly check the puller arms for wear and breakage.
- Keep the threaded bolt in the pressure rod clean at all times and lubricate it regularly.

9.5 Change of wear plates



ATTENTION

The wear plates have a defined curvature. To prevent premature wear by the rotary lobes, the correct installation position of the wear plate must be observed during installation → Fig. "Installation position of the curved wear plates".



Tightening torque

Wear plate screws: **20 Nm**

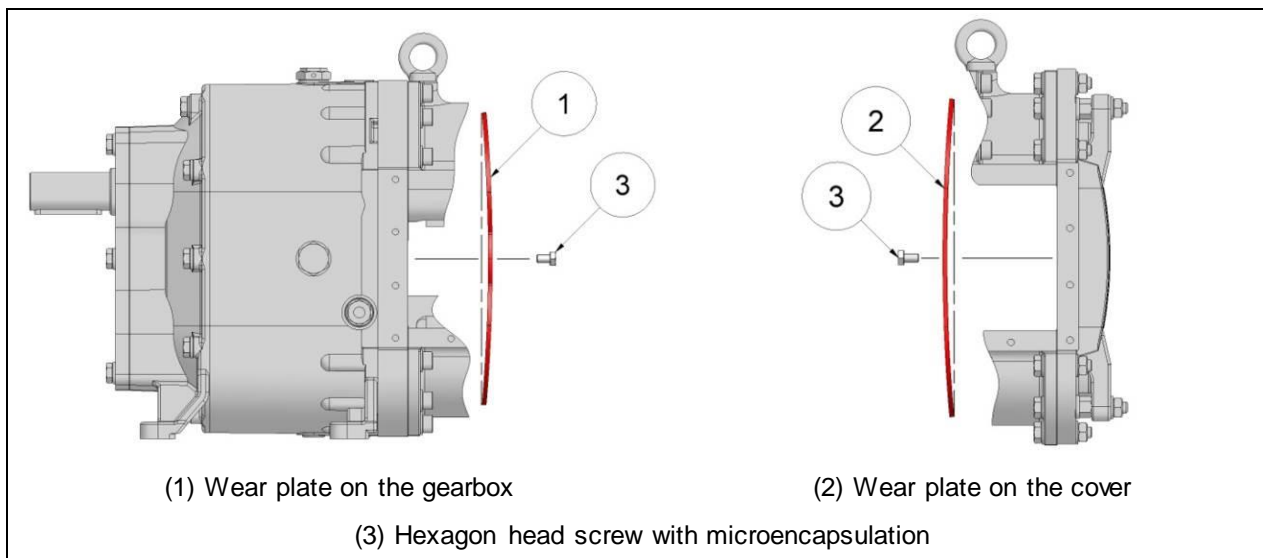

Fig. 25: Installation position of the curved wear plates

9.6 Change of cartridge mechanical seal



Cartridge mechanical seal – installation/disassembly tool: Part no. WKZ0455

→ Fig. "Cartridge mechanical seal on the gearbox"

1. Depressurise the buffer chamber if necessary → Chap. "Buffer chamber".
2. Drain and clean the buffer chamber.
3. If locking screws or flushing connectors for the circulation system are fitted, dismount them → Chap. "Circulation system on the cartridge mechanical seal" and → Fig. "Flushing operation".
4. Drain gear oil.
5. Follow the steps specified in → Chap. "Rotary lobe change" and "Wear plate change".
6. Remove the slotted set screws (1) of the cartridge mechanical seal (Fig. a)).
7. Put on installation tool (A) and screw the cylinder head bolts (2) into the extracting boreholes of the cartridge mechanical seal (Fig. b)).
8. Smoothly pull out the cartridge mechanical seal using the three hexagon head bolts (3) of the installation tool (Fig. b)).
9. Before installing the new cartridge mechanical seal, carefully remove the burrs on the keyways and clean the cartridge mechanical seal seat in the housing.
10. Push new cartridge mechanical seal onto the shaft. Carefully oil the outer O-rings on the seal carrier (pos. 4 in Fig. b)) before installation. Attention: Do not use mineral oil or grease for O-rings made of EPDM. Use glycol as an alternative.
11. If a circulation system is present, the flushing connector boreholes in the cartridge mechanical seal must be aligned with the flushing connector boreholes in the bearing seal housing.
12. To install the new cartridge mechanical seal, place the installation tool on the cartridge mechanical seal without bolts.
13. Push rotary lobe (without fitting key) onto the shaft.
14. Insert the pressure disc and the cylinder head bolt.
15. Tighten the rotary lobe until the cartridge mechanical seal is flush with the pump housing.
16. Reinstall any removed locking bolts or flushing connectors.
17. Remove the rotary lobe again.
18. Push O-ring and support ring onto the shaft.
19. Before installing the rotary lobes, thoroughly clean the contact surfaces of the rotary lobes and the seal.
20. Install rotary lobes, wear plates and Q cover.
21. Top up buffer or quenching fluid.
22. Readjust the pressure in the buffer chamber if necessary → Chap. "Buffer chamber".
23. Top up the gear oil.

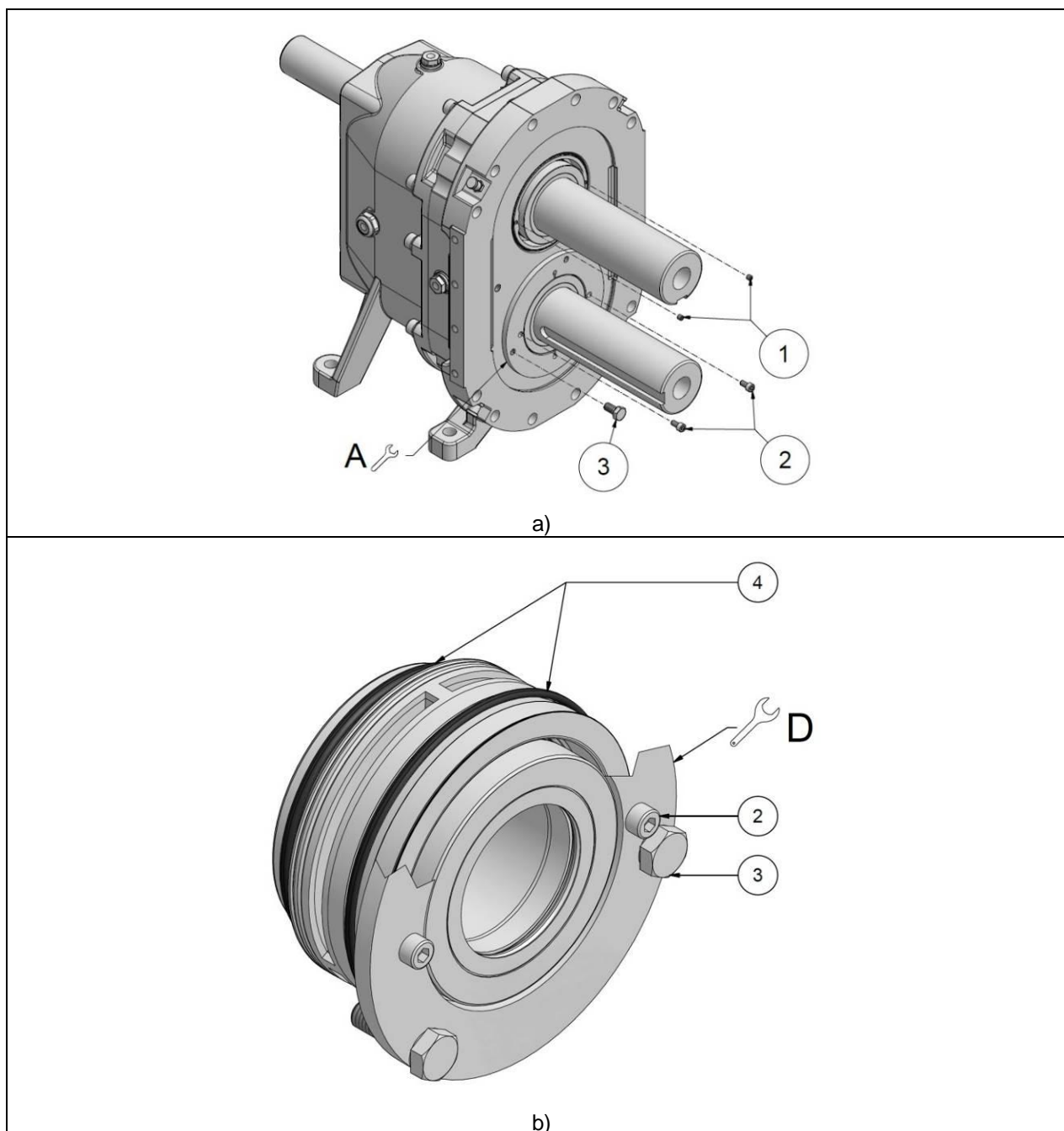

Fig. 26: Cartridge mechanical seal on the gearbox

- | | | | |
|---|---------------------|---|--------------------------------|
| 1 | Set screw | 4 | O-ring (seal carrier) |
| 2 | Cylinder head bolt* | A | Installation/disassembly tool* |
| 3 | Hexagon head bolt* | | |

* included in tool with part no. WKZ0455

9.7 Closing the Q cover

→ Fig. "Opening/closing the Q cover"

1. Thoroughly clean the contact surfaces before installing the Q cover (2).
2. Pull the O-ring (3) onto the Q cover.
3. Set the Q cover in place.
4. Install and tighten the hexagon nuts (1) again.

Attention! Do not tilt the Q cover while doing this, but press it evenly by hand (no tools). Make sure the O-ring is seated correctly.

9.8 Adjusting of pump housing segments

The pump housing segments of the Vogelsang rotary lobe pump can be adjusted to reduce the top clearance between the rotary lobe and the pump housing segment. The top clearance must be at least as large as one adjustment.

1. Remove the Q cover → Chapter "Opening the Q cover".
2. Undo the connectors and bolts on the pump housing segments.
3. Shift the spring pins of the upper and lower pump housing segments to both sides → Fig. "Adjustment of pump housing segments".
4. Before installation of the pump housing segments, apply flange sealant, set a flat gasket in place and coat that gasket with flange sealant as well.
5. Screw all bolts back onto the pump and the connectors → Chapter "Pump connector".
6. Install the Q cover → Chapter "Closing the Q cover".

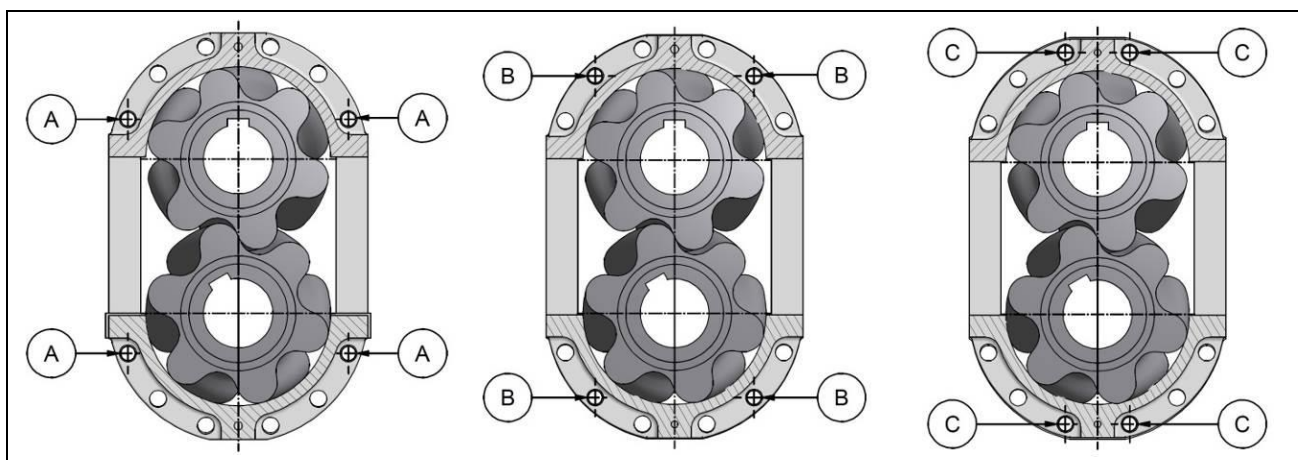

Fig. 27: Adjustment of pump housing segments

Position of the spring pin

- A** In the condition of the pump on delivery
- B** In the 1st adjustment (reduction of the head gap by 0.5 mm)
- C** In the 2nd adjustment (reduction of the head gap by 1.0 mm)

9.9 Reducing the starting torque

The starting torque can be reduced by installing shims between lobes and wear plates.
Please note: increasing the gap between lobes and wear plates reduces the volumetric efficiency.

Increasing the gap → + 0.2 mm on the Q cover:

Put one new shim 8 x 14 x 0.2 (NUS.063) on each of the four distance nuts of the Q cover.

Increasing the gap → + 0.2 mm on the gearbox:

1. Replace existing shim 45 x 55 x 0.3 (part no. NUS.033) with new shim 45 x 55 x 0.5 (part no. NUS.056).
2. In addition put one shim (part no. NUS.033) on each of the four distance nuts of the Q cover to adjust the gap accordingly.

Attention! If more than two shims are placed on each distance nut of the Q cover, a thicker O-ring (part no. DOR.092) must be placed under the Q cover to maintain reliable sealing.

In case of wear on lobes or plates, the gaps can be reduced again accordingly.

10 Troubleshooting

10.1 Troubleshooting

Troubleshooting

| | |
|--|---|
| <ul style="list-style-type: none"> • No pump delivery • Pump stops after start • Intake flow breaks away after start • Irregular pump delivery • Capacity too low • Pump blocked • Power consumption too high • Drive belt slips • Leakage on the pump • Pressure and level variations in the buffer chamber • Leakage at the mechanical seal • Extreme pressure and level changes in the buffer chamber • With a dry buffer chamber: buffer chamber tank more than half full • Pump too hot • Motor too hot • Noises & vibrations | <p>Help → Chapter "Help"</p> <p>A, B, D, E, G, J, R</p> <p>J, K, M, R, S, V</p> <p>D, E, G, S, V</p> <p>D, E, G, J</p> <p>D, G, J, R, S, T, U</p> <p>C, F, J, K, M, R, U, V</p> <p>C, M, R, S, V</p> <p>F, H, M, R, S</p> <p>C, R, U</p> <p>O, U, V, W</p> <p>P, W</p> <p>P</p> <p>Q</p> <p>A, C, M, N, R, S, U</p> <p>C, K, L, M, R, S, V</p> <p>C, D, E, F, G, I, J, K, M, N, R, S</p> |
|--|---|

10.2 Help

| | Possible cause | Possible remedy | Observe notices and safety notes → Chapter |
|----------|--|--|--|
| A | Pump is not priming | Fill the pump with fluid. | |
| B | Incorrect direction of rotation | Change the pump's direction of rotation. | "Flow direction" |
| C | Pipe causing pump housing warping | Check the orientation of the pipe to the pump. If necessary, provide a compensator or secure the pipe. | "Installation in pipes" |
| D | Leakage in the suction pipe | Check the suction-side pipe system for leakage. | |
| | Gas formation | Vent the suction pipe and pump chamber, top up fluid. | |
| E | Suction pipe clogged | Check the free flow of the pipe system on the suction side. | |
| F | Foreign matter in medium | Clean the pump unit. Install strainer in the suction pipe. | |
| G | NPSH _a too low (medium evaporates during feeding) | Increase the suction pipe diameter, shorten the suction pipe length, simplify suction pipe assembly, reduce the suction height, reduce the speed, adjust the medium temperature. | "Installation in pipes" |
| H | Belt tension too low | Tighten in accordance with manufacturer's specifications. | "Base, support surface for machine" |
| I | Coupling not correctly aligned | Check the orientation and align according to manufacturer's specifications if necessary. | |
| J | Belt drive slips | Tighten in accordance with manufacturer's specifications. | |

| | Possible cause | Possible remedy | Observe notices and safety notes → Chapter |
|----------|--|---|--|
| K | Faulty electrical connection | Check electrical equipment. | "Drive" |
| | Error in the hydraulic system | Check the hydraulics. | |
| L | Motor speed too low during variable frequency drive operation | Install external fan, increase motor speed. | "System control": Variable frequency drive operation |
| M | Stiff running caused by swollen lobe elastomer | Check the medium resistance of the lobe elastomer. | "Specifications": Material description for rotary lobes |
| | Stiff running caused by accumulation of solid matter in the gaps | Clean pump chamber; increase the gaps → Chapter "Reducing the starting torque"; adjust the drive. | "Repair", "Drive" |
| N | Oil level in the gearbox is not OK | → Chapter "Gearbox" | "Maintenance" |
| O | Operation-related fluctuations in buffer chamber | → Chapter "Buffer chamber" | "Maintenance" |
| P | Mechanical seal damage | Change the mechanical seal, → Chapter "Cartridge mechanical seal change" | "Repair" |
| | Faulty repair of the mechanical seal | | |
| | Buffer fluid tank leaking | Check buffer fluid tank for leaks. | "Maintenance" |
| Q | Seal leaking | → Chapter "Dry buffer chamber" | "Maintenance" |
| R | Differential pressure too high | Reduce differential pressure. | "Specifications" |
| S | Medium viscosity above the nominal value | Reduce speed. Increase medium temperature. | "Intended use" |
| T | Medium viscosity below the nominal value | Increase speed, decrease medium temperature, replace wear parts. | "Repair" |
| | Gaps too large | Reduce gaps → Chapter "Reducing the starting torque" but with the procedure reversed | "Maintenance" |
| U | Medium temperature above the nominal value | Reduce medium temperature. | "Intended use", "Specifications": |
| V | Medium temperature below the nominal value | Increase medium temperature (after consulting Vogelsang). | Material description for rotary lobes |
| W | Mechanical seal elements not in the best position | Pressurise the buffer chamber once with the max. permissible buffer chamber pressure (tank pressure) (single mechanical seal: 5 bar, double mechanical seal: 10 bar). Then restore the design pressure. | "Buffer chamber" "Pressurisable buffer fluid tank" |
| | | Put the buffer chamber into operation in its non-pressurised state (buffer fluid tank closed) and observe the buffer chamber fluid level and pressure. | |
| | | Adjust the tank pressure (buffer chamber pressure) to be higher than its design pressure. Observe max. permissible buffer chamber pressure (tank pressure): Single mechanical seal: 5 bar, double mechanical seal: 10 bar | |

11 Putting out of operation and disposal

1. Disconnect pump from the power supply or the PTO drive. Observe notices and safety notes → **Chapter "Drive"**.
2. Disconnect pump from the pipe. Observe notices and safety notes → **Chapter "Installation in pipes"**.



WARNING

Risk of injury by crushing or impact!

Pipes under flexural strain can spring back under spring energy.



- Personnel must wear suitable protective clothing.
- Take care when undoing screws and bolts.

3. Drain working materials.
 - Drain the gear oil from the pump gearbox. Observe notices and safety notes → **Chapter "Gear oil – inspection and change"**.
 - Drain the buffer or quenching fluid from the buffer chamber. Observe notices and safety notes → **Chapter "Draining and cleaning the buffer chamber"**.
4. Drain the pump and remove residual medium. Observe notices and safety notes when opening the pump cover → **Chapter "Repair"**.



Environmentally friendly disposal

Working materials such as oils, hydraulic fluids and dangerous media should be treated as hazardous waste and disposed of properly.

5. Hand over the pump for scrap. Observe notices and safety notes → **Chapter "Transport, storage"**.

Maintenance and service plan

12 Maintenance plan

12.1 Maintenance instructions



ATTENTION!

Carefully observe the following maintenance instructions and, if applicable, document them in the service plan → **Chap.** "Service plan".

Safety devices must be checked on a regular basis to ensure that they are functioning correctly, especially after maintenance and repair work and before start-up.

Observe and comply with **the maintenance instructions in the relevant documents** → Chap. "Relevant documents".

Change the buffer or quenching fluid **if it is severely contaminated**.

If the machine's **running noise changes** or if vibrations occur → Chap. "Troubleshooting".

To avoid the adhesion of the mechanical seal rings' sealing surfaces, the shaft on **new pumps with a mechanical seal with SiC-SiC material combination** that are not put into operation immediately needs to be turned (at least one revolution) about every two months.

12.2 Maintenance intervals



ATTENTION!

Carefully observe the following maintenance intervals and document them in the service plan → **Chap.** "Service plan".

Before start-up:

Check pump/motor (coupling) orientation (base C)

After the first 20 operating hours:

- Retighten the bolts and screws fastening the pump connectors
- Retighten the bolts and nuts securing the machine (without base)
- Retighten the bolts and nuts fastening the motor and the machine on the base
- Check fixed coupling of coupling guard (base C)
- Check the buffer or quenching fluid
- Change the gear oil

Every 200 operating hours:

Check the buffer or quenching fluid

Every 500 operating hours, at least once every three months:

Check the gear oil

Every 2000 operating hours, at least once a year:

- Retighten the bolts and screws fastening the pump connectors
- Retighten the bolts and nuts securing the machine (without base)
- Retighten the bolts and nuts fastening the motor and the machine on the base
- Check fixed coupling of coupling guard (base C)
- Check pump/motor (coupling) orientation (base C)
- Change the buffer or quenching fluid
- Change the gear oil

12.3 Additional maintenance intervals for pumps with belt drive

See also “Technical information for belt drives TINF.PU.020.xx”.

Before start-up and after long periods of shutdown:

Check belt tension and belt orientation

After 0.5 to 4 operating hours:

Check belt tension

Every 6 months:

- Check belt tension
- Check belts and pulleys for wear. In the event of clear signs of wear, check the belt orientation.

VOGELSANG



Vogelsang GmbH & Co. KG

Holthöge 10-14
49632 Essen/Oldb.

Phone: +49 (0) 54 34 83 0
Fax: +49 (0) 54 34 83 10

www.vogelsang.info
info@vogelsang.info

ENGINEERED TO WORK

Australien
Vogelsang Pty. Ltd.
vogelsang.com.au

Brasilien
Vogelsang Brasil Ltda.
vogelsang.com.br

China
Vogelsang Mechanical Engineering (Shanghai) Co., Ltd.
vogelsang.com.cn

Dänemark
Vogelsang A/S
vogelsang-as.dk

Deutschland - Niederlassung Ost
Vogelsang Lutherstadt Eisleben
vogelsang.info

Finnland
Vogelsang Oy
vogelsang.fi

Frankreich
Vogelsang France S.A.R.L.
vogelsang.fr

Großbritannien
Vogelsang Ltd.
vogelsang.co.uk

Indien
Vogelsang India Private Limited
vogelsangindia.com

Irland
Vogelsang Ireland
vogelsang.ie

Italien
Vogelsang Italy Srl
vogelsang-srl.it

Malaysia
Vogelsang Malaysia
vogelsang.info

Mexico
Vogelsang De México S.de R.L. de CV
vogelsang.mx

Niederlande
Bos Benelux BV
b.bos@bosbenelux.com

Österreich
Vogelsang Austria GmbH
vogelsang-austria.at

Polen
Vogelsang Poland Sp. z o.o.
vogelsang.pl

Rumänien
Vogelsang Romania SRL
vogelsang.ro

Russland
OOO Vogelsang Russland
vogelsang.ru

Slowenien
VGS TECH GREGOR TURSIC S.P.
vogelsang.info

Schweden
Vogelsang Sverige AB
vogelsang.se

Spanien
Vogelsang S.L.
vogelsang.es

Südkorea
Vogelsang Korea Co., Ltd.
vogelsang.co.kr

Tschechische Republik
Vogelsang CZ s.r.o.
vogelsang-czech.cz

USA
Vogelsang USA Ltd.
vogelsangusa.com