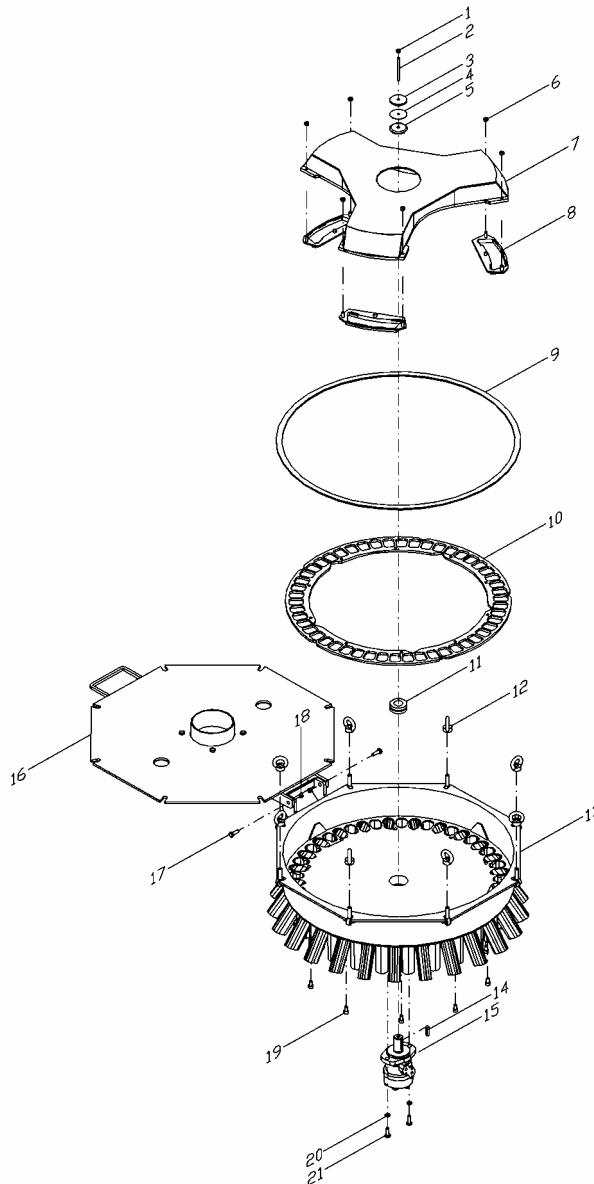

DOSIMAT ø 800
Ersatzteil-Liste
Spare Parts List
LV38 / LV40 / LV44 / LV45 / LV50 DN50
Sternrotor / star rotor

Vogelsang Deutschland West
D-49632 Essen (Oldb.)
Tel.: +49 5434-83-0
Fax: +49 5434 83 10
info@vogelsang-gmbh.com
www.vogelsang-gmbh.com

Vogelsang Deutschland Ost
D-06295 Rothenschirmbach
Tel.: +49 3 47 76 2 05 81
Fax: +49 3 47 76 2 05 82
rsb@vogelsang-gmbh.com

Vogelsang Dänemark
DK-6880 Tarm
Tel.: +45 97 37 27 77
Fax: +45 97 37 30 77
vogelsang@adr.dk

1/2

Ausgabe: 30.09.2004
Ausdruck: 30.09.2004
Kopie von etl_dm-800-38-50-st_de-
gb_90997.doc
Copyright © 2001

Vogelsang USA
USA-Ravenna, OH 44266
Tel.: +1 330 296 3820
Fax: +1 330 296 4113
sales@vogelsangusa.com
www.vogelsangusa.com

Vogelsang England
GB-Crewe, Cheshire CW1 6EW
Tel. +44 1270 216 600
Fax: +44 1270 216 699
sales@vogelsang.co.uk
www.vogelsang.co.uk

Vogelsang Frankreich
F-26740 Montboucher Sur Jabron
Tel: +33 673 615 864
jean-marie.giordan@wanadoo.fr

Pos	Art.-Nr. Art.-No.	Beschreibung	Description	Stück Piece	LV 38 DN50	LV 40 DN50	LV 44 DN50	LV 45 DN50	LV 50 DN50
1	NMK.004.E	Mutter M8 V2A, selbstsichernd	hex. nut M8 V2A, self-locking		1	1	1	1	1
2	NGS.012	Gewindestift M8 x 60 V2A	set screw M8 x 60 V2A		1	1	1	1	1
3	NUS.001	Vorspannscheibe	pretension disk		1	1	1	1	1
4	DFD.044	Gummischeibe t=1	rubber disk t=1		1	1	1	1	1
5	TGD.004	Gummischeibe t=10	rubber disk t=10		1	1	1	1	1
6	NMS.021	SKT-Mutter M10 (in TMS enthalten)	hex. nut M10 (included in TMS)		6	6	6	6	6
7	TRO.064.N2	Sternrotor 200 mm breit	rotor 200 mm width		1	1	1	1	1
8	TMS.127	Messer kpl. 200 mm breit	knife, complete 200 mm width		3	3	3	3	3
9	DFD.021	Dichtung (Meterware)	gasket (yard goods)		2.6m	2.6m	2.6m	2.6m	2.6m
10	TFL.380	Schneidring LV38 DN50	cutting ring LV38 DN50		1	-	-	-	-
	TFL.377	Schneidring LV40 DN50	cutting ring LV40 DN50		-	1	-	-	-
	TFL.434	Schneidring LV44 DN50	cutting ring LV44 DN50		-	-	1	-	-
	TFL.432	Schneidring LV45 DN50	cutting ring LV45 DN50		-	-	-	1	-
	TFL.665	Schneidring LV50 DN50	cutting ring LV50 DN50		-	-	-	-	1
11	DFD.083	Dichtung	gasket		1	1	1	1	1
12	NMK.009	Ringmutter M12	lifting-eye nut M12		8	8	8	8	8
13	TGE.063.N2	Gehäuse LV38 DN50	housing LV38 DN50		1	-	-	-	-
	TGE.064.N2	Gehäuse LV40 DN50	housing LV40 DN50		-	1	-	-	-
	TGE.066.N2	Gehäuse LV44 DN50	housing LV44 DN50		-	-	1	-	-
	TGE.067.N2	Gehäuse LV45 DN50	housing LV45 DN50		-	-	-	1	-
	TGE.068.N2	Gehäuse LV50 DN50	housing LV50 DN50		-	-	-	-	1
14	NKS.001	Schmiernippel	grease nipple		1	1	1	1	1
15	AOM.017	Hydraulikmotor OMS 200	hydraulic motor OMS 200		1	1	1	1	1
16	TDE.007N1	Deckel	cover		1	1	1	1	1
17	NSK.029	Sechskantschraube M12 x 35	hex. head cap screw M12 x 35		2	2	2	2	2
18	NMK.002	Mutter M12, selbstsichernd	hex. nut M12, self-locking		2	2	2	2	2
19	NSI.017	Zylinderschraube M10x16	cap screw M10x16		10	10	10	10	10
20	NFR.004	Federring M12	washer M12		2	2	2	2	2
21	NSK.029	Sechskantschraube M12 x 35	hex. head cap screw M12 x 35		2	2	2	2	2